

MATCHING OF PULSE FORMING NETWORK AND PULSE TRANSFORMER PARAMETERS IN PULSE MODULATOR CIRCUITS FOR A KLYSTRON POWER SUPPLY

I.V. Kazarezov, A.A. Korepanov

Budker Institute of Nuclear Physics, SB RAS, Novosibirsk, Russia

The most widespread circuit of high-power microsecond pulse generation for a power supply of various pulse microwave devices is the circuit of line type modulator on the basis of an artificial pulse forming network (PFN), switch and step-up pulse transformer (PT). The efficiency of the modulator is defined both by active losses in elements of the generator and losses of energy at pulse rise and fall time generation, the influence of energy losses associated with pulse rise and fall generation being the most essential. Pulse forming efficiency, taking into account the given losses, is determined as follows:

$$\eta = \frac{W_{top}}{t_{bot} \int_0^{t_{bot}} u(t)i(t)dt} \quad (1)$$

Here W_{top} is an energy, dissipated in a load at a pulse top generation (the pulse top is determined with the given accuracy); t_{bot} is the pulse duration at the bottom. It is clear from (1), that increase in energy efficiency requires reducing the pulse rise and fall times at the given pulse top duration. The basic parameters having influence on the pulse rise and fall times are time constant of a transformer circuit, PFN type, and number of its cells. The paper deals with a choice of the specified parameters.

TIME CONSTANT OF A TRANSFORMER CIRCUIT AND CHOICE OF PFN TYPE

It is shown in [1] that with a sufficient accuracy the processes of pulse rise and fall forming by PT may be analyzed using the simplified circuit, shown on Fig. 1. All parameters of the equivalent circuit are reduced to the secondary winding. Here

$LS = Lst + Ls1$ is a sum of PT leakage inductance Lst and inductance of a primary circuit $Ls1$,

$C = C_T + C_2$ is a sum of PT dynamic capacitance

C_T and capacitance of a load C_2 , $R1$ and $R2$ are resistance of the generator and load, accordingly. The time constant of a transformer circuit is determined in view of parasitic parameters of the primary and secondary circuits:

$$\tau = \sqrt{(Lst + Ls1)(C_T + C_2)} \quad (2)$$

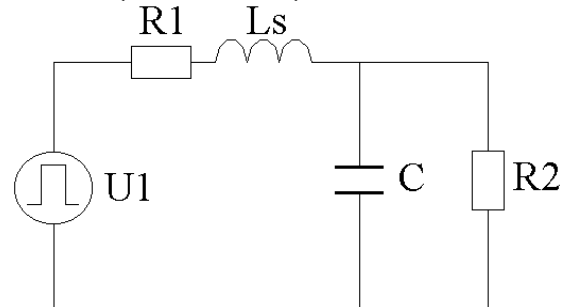

Fig. 1: Equivalent schematic of a transformer circuit.

One of the basic issues of the pulse modulator designing is a choice of PT transformation ratio or, for the specified parameters of the switch, of PFN type. The most widespread type of power microsecond PT's windings is one layer winding with additive polarity. It is known (see, for example, [1]), that dynamic capacitance of such windings is proportional to

$$C_T \sim (n - 1)^2 / n^2 \quad (3)$$

and the inductance does not depend on n at all. Thus, if the influence of the primary circuit inductance $Ls1$ is neglected, the dependence between the time constant τ and PT transformation ratio n will be

$$\tau \sim \sqrt{c_1 \left(\frac{n-1}{n} \right)^2 + C_2} \quad (4)$$

Here the constant c_1 does not depend on n . This relation shows, that the time constant of a transformer circuit grows weakly at n increase. For example, at PT transformation ratio variation from 14 down to 7 the time constant τ can increase maximum by 1.08 times (at zero load capacitance C_2). However, in general it is necessary to take into account the influence of $Ls1$ on increase of pulse rise time. Inductance of a primary circuit $Ls1' = Ls1/n^2$ (the values reduced to the PT primary side are marked with primes) mainly consists of thyatron inductance and inductance of connections between PFN, thyatron, and PT. The correct analysis of dependence between value of $Ls1'$ and n is hindered, as this inductance does not linearly depend on a voltage, therefore further, for simplicity, it is supposed, that $Ls1'$ does not depend on a primary voltage, so does not depend on PT ratio. This assumption will give an upper-bound estimate for τ dependence on n . Really, at given $Ls1'$ value a relation for time constant (2) can be copied as follows:

$$\tau = \sqrt{(Lst + Ls1' \cdot n^2) \cdot \left(c_1 \left(\frac{n-1}{n} \right)^2 + C_2 \right)} \quad (5)$$

This equation shows that at large n the influence of $Ls1$ on time constant can be significant. Therefore double PFN (DPFN, also called Blumlein PFN) with an output voltage equal to charged one should be used for PT turns ratio decrease and primary voltage increase. It should be noted, that DPFN has the disadvantages:

- The voltage polarity reversal on capacitors of the first part of DPFN results in reduction of their lifetime;
- Increased losses in the DPFN's first part, connected with increased duration and amplitude of a current, passing through it;
- High-voltage performance of a PT primary winding and connections with DPFN becomes complicated;
- More energy, than in the circuit with single PFN, is disappeared at klystron during its breakdown; the protection circuits become complicated;
- At least double quantity of network elements is required, that complicates and gets up DPFN performance.

As it follows from the above, at given parameters of the switch it is better to use a single PFN instead of DPFN, if pulse distortions (the tightening of rise and fall) are almost identical.

In terms of the generator, which supplies a klystron for the project of the linear collider JLC [3], the comparison of the pulse shape and energy efficiency for the pulse formers based on single and double PFNs with two PT turns ratios 14 and 7 accordingly was carried out. Parameters of the pulse on a load are:

Voltage amplitude – 560 kV

Current amplitude – 503 A

Pulse top duration – 1.5 μ s

PT leakage inductance and total capacitance of a secondary circuit are taken from [2]: $Lst = 120 \mu$ H, $C = 250$ pF. For simplicity during simulation the magnetization current may be ignored. The number of cells in both PFN circuits was chosen as 20 (in DPFN 2x20). The increase of capacitance C at PT ratio by the factor of 2 can be neglected, as PT capacitance makes only $\sim 1/3$ of the total capacitance C .

Table 1: Pulse shape efficiency in the circuits of single and double PFN.

$Ls1', \mu$ H	0.4	0.5	0.6	0.8	1
η_{single} (n=14)	0.782	0.78	0.77	0.757	0.749
η_{double} (n=7)	0.777	0.776	0.775	0.764	0.752

Therefore during numerical simulation of two PFN circuits they differ only in additional inductance of a primary circuit $Ls1 = Ls1' \cdot n^2$. The analysis results of these circuits are given in Table 1. From the given table it follows, that pulse shape efficiency in the single PFN circuit η_{single} is not worse than in the double PFN

η_{double} down to primary circuit inductance values

$Ls1/Ls \approx 1$ (at $n = 14$) or $Ls1/Ls \approx 0.25$ (at

$n = 7$). Thus, in the case of identical efficiencies a

single PFN is favoured.

The features of PFN designing for powerful generators with PT are the fixed parameters of a transformer circuit: its total inductance and capacitance. To obtain high energy efficiency, PFN parameters (cells inductance and capacitance) should be such that the rise time is determined mainly by parameters of a transformer circuit, but not by PFN parameters. The influence of finite time of switch triggering on the pulse rise time may be ignored, since in most cases thyratrons have turn-on time several times smaller than pulse rise time. The technique of PFN cell number choice can be illustrated by the example of a single PFN. The circuit of single PFN with the equivalent schematic of a transformer circuit and resistive load is shown on Fig.2.

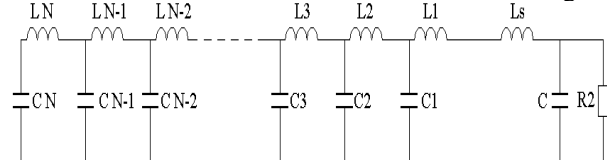

Fig. 2: Simulated circuit of a single PFN.

The energy efficiency η dependence of a single PFN cells number N at various time constants of a transformer circuit (the characteristic impedance of this circuit was set approximately equal to the load resistance) was obtained (Table 2) as a result of numerical simulations of transient processes in the given circuit.

CHOICE OF PFN CELL NUMBER

Table 2: Energy efficiency dependence on SPFN cells number at various values of transformer circuit time constant.

τ/t_p	η	N
0.05	0.82	10
	0.87	20
	0.884	30
0.075	0.814	15
	0.83	20
	0.843	25
0.1	0.775	10
	0.79	15
	0.79	20

The top non-uniformity in this case was about $\pm 1\%$. The data obtained allow us to choose the number of cells necessary to reach the maximum efficiency when the transformer circuit time constant is fixed. As follows from Table 2, for any transformer circuit time constant there is a value of cell number N , over which the energy efficiency does not practically change. Therefore the choice of too large value of N is not justified from the point of view of rise time and efficiency. Moreover current load over the capacitors of a network is increased when number of cells is increased. It is connected with reduction of duration of current pulses through capacitors at increase of cell number.

Besides, increase of network cell number can result in gain of influence of PFN capacitor parasitic inductance Lc . The pulse shape efficiency falls because of tightening of a pulse fall time. The Lc/L_0 value dependence of η was investigated by the example of 10-cell single PFN, loaded on matched resistive load. The non-uniformity of a pulse top was maintained at a level of $\pm 1\%$. The results of these simulations are shown on Fig.3. The inductance Lc

grows up $\sim N$, and the cell inductance L_0 falls $\sim 1/N$ when cells number N increases. Therefore at increase of N the drop of efficiency due to capacitor inductance Lc will increase.

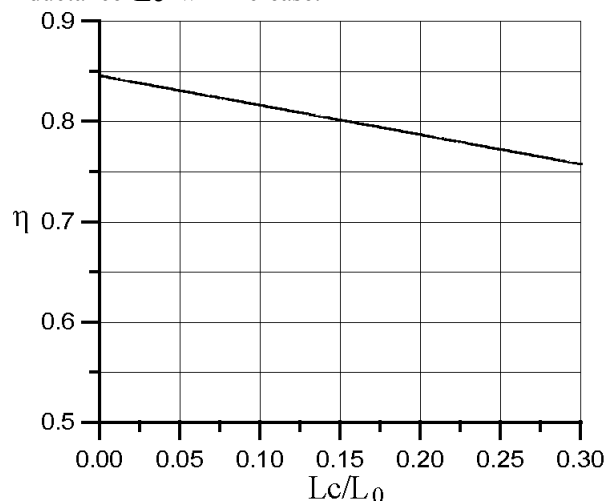

Fig. 3: The energy efficiency versus parasitic inductance of 10-cells SPFN capacitors.

Thus, a conclusion may be drawn: the time constant of a transformer circuit determines unambiguously a number of PFN cells, at which a pulse has the best characteristics.

REFERENCES

- [1] Vdovin S.S. Pulse transformers design. "Energy", Leningrad, 1971, p. 148.
- [2] Pulse transformer R&D for NLC klystron pulse modulator. / M. Akemoto, S. Gold, A. Krasnyh and R. Koontz, Stanford Linear Accelerator Center, SLAC-PUB-7583, July 1997.
- [3] M. Akemoto, S. Tokumoto, S. Anami, M. Mizuno. Blumlein type of modulator at KEK. - Third Annual Klystron-Modulator Workshop, June 23-25, 1998, Workshop paper.