

LINAC FAILURE DIAGNOSTICS

Yu.I.Akchurin, V.N.Boriskin, M.V.Ivahnenko, S.P.Levandovsky, E.I.Orlova, A.N.Savchenko
NSC KIPT, Kharkov, Ukraine

The data processing subroutine from 60 discrete detectors is developed for the operating control system [1] of the technological linac. It uses a dialogue regime of work. This subroutine allows us to find a basic cause of linac failures in certain circuit, as well as the site of fault. Recommendations for repair are also given.

The information is submitted to a customer as mnemoschemes and various tables.

The Failure Table consists of 4 pages containing more than 70 messages. When the linac failure happens the operator begins a dialogue with the computer. Herewith a part of this table appears on the screen of display. It is connected with linac condition at this time as an object of control and indicates what is enclosed, and what is blocked. The exclamation point near message indicates that this is a basic cause of certain circuit of failures, enumerating on the screen.

The subroutine has a two-level menu. First level is a list of failures, second level is a description for the operator, and, besides, for the repair personnel it names a module and defines the place of checking a signal (the Commentary Table). The total volume of commentaries is 25 pages (500 lines).

The Interlock Table gives all the necessary information on the interlock reason of each control object. It consists of 7 pages. The volume of the Reference Table is also 7 pages. It is destined for the repair personnel. The whole necessary information for the repair of the interface block and the whole linac control system is concentrated in this table.

The operator receives also the appropriate prompt like "Is the object off? Check" from the Check Signal Table. All auxiliary objects, which must be turned on to get a permission to turn on a main object, are enumerated in the prompt. The volume of this table consists of 3 pages.

And, finally, the places of location of detectors of interlock, operated to the moment of demonstrations, are indicated by red spots on the linac structure scheme (Fig. 1). As far as our linac is located in 5 premises on 3 floors such a program service greatly relieves a troubleshooting in systems.

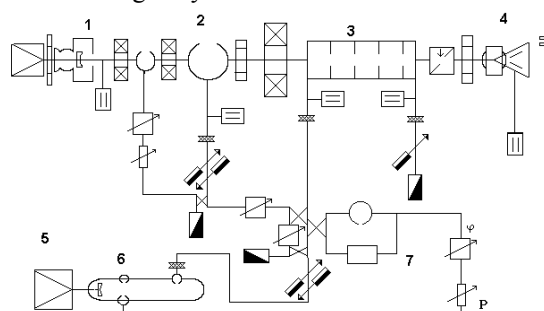

Fig. 1. The linac structure scheme.

1 – injector, 2 – resonator, 3 – acceleration section, 4 – scanner, 5 – modulator, 6 – klystron, 7 – trigger generator, ϕ – phase shifter, P – attenuator.

Fragment of the Failure Table

Detector number	Text on the display screen
3	Interlock of high voltage klystron
5	Interlock of high-frequency field
15	There is no klystron focusing (Klystron is focus out)
16	There is no klystron heat
20	Klystron and tiratron catode is non-warmed-over (15 minutes)
23	Vacuum klystron pump is inactive
33	There is no water in focused klystron solenoid

Fragment of the Commentary Table

Commentaries	Information source	Place of signal checking
20 Klystron and tiratron catode is non-warmed-over (15 minutes) It passed 9 minutes for catodes to warm up	Module of out triggers	Plate BH C-16
23 Vacuum klystron pump is inactive or there is no high voltage on his anode	Power module of the vacuum pump	X11.1:33

Fragment of the Interlock Table

Detector number	Reason of the interlock	Upper limit	Text on the indicator	Interlock object
38	Vacuum klystron pump is inactive or there is no high voltage on his anode	3KV	Klystron pump	Klystron heat
40	There is no firing impulse of tiratron	7V	Firing	High voltage klystron

Fragment of the Reference Table.

Indicator number on façade	Text on indicator	Text on the display screen	Information source	Logic level	Interlock object	Place of signal checking
52	Firing	There is no firing impulse of tiratron	The firing control socket	1	High voltage klystron	X11.1:7
19	NKL klystron	There is no klystron heat current	Comparator module	0	High voltage klystron	XS6/b31

Fragment of the Check Signal Table.

Detector Number	Text on the indicator	Indicator number	Place of signal checking	Register and bit number
1	Is the NKL klystron off ? Check: Klystron pump	L 24	X11.1:33	4IN 6P
2	Focusing klystron	L 18	XS6:c10	5IN 6P
3	Klystron vacuum 1 minute	L 58	KLH v13,v15	

REFERENCES

[1] V.N.Boriskin et al. Control system for a linear resonance accelerator of intense electron beams // Nucl.

Instr. and Nucl. Instr. and Meth. in Phys. Res A 352 (1994) 61-62.