

# CREATION AND DEVELOPMENT OF THE LOCAL INFORMATION COMPUTER NETWORK OF INSTITUTE OF HIGH ENERGY PHYSICS AND NUCLEAR PHYSICS NSC KIPT

*V.A. Dudnik, E.V. Krivorukov, V.I. Kudrjavitsev, T.M. Sereda, S.A. Us, M.V. Shestakov*

*National Science Center "Kharkov Institute of Physics and Technology", Kharkov, Ukraine*  
e-mail: dudnik@kipt.kharkov.ua

Results and the basic stages of creation and development of local information computer network at Institute of High Energy Physics and Nuclear Physics NSC KIPT for last five years are submitted. The purpose of work was increase of an overall performance of researchers due to rational use of resources and creation on base local information computer network of shared system. In article obtained experience and specificity of realization of such systems is reflected.

PACS: 13.75Gx

## INTRODUCTION

The history of use of computer facilities, and in particular, its applications for automation and processing's of results of scientific and technical researches testifies that at all stages of development it was necessary to search for the compromise between mutually exclusive requirements: maximum favorable interface for users and an effective utilization technical and software. The first computers were exclusively given the user, but thus the extremely expensive technical equipment was used very inefficiently. Therefore shared systems in which the technical equipment was used very effectively have been created, but numerous users frequently slowed down work each other, and efficiency of their work fell. Therefore in process of reduction in price of hardware of computer facilities (CF) and with the advent of personal computers (PC) the rational decision was return to exclusive use of means of the CF.

However practice has shown, that, despite of a wide circulation of personal computer facilities, nevertheless, collective use of computing means in many cases gives a positive effect - as due to expansion of opportunities of users and increase of efficiency of their work, and for the account of more rational use of the equipment.

In IHEPNP NSC KIPT creation and development of shared systems has old traditions. However in new conditions - a wide circulation of personal computers on the one hand, and absence of powerful computer complexes - with another, the shared system should be built on the basis of technical equipment and the software initially intended for personal calculations that generates set of difficulties in the organization of reliable and effective work of such systems. In article experience and specificity of realization of such systems is reflected.

## LOCAL INFORMATION COMPUTER NETWORK AS A BASIS OF SHARED SYSTEM

The means to transform group of separate personal computers in the coordinated multi-user computer system, the local information computer network (LICN) is capable. The user connected to a network, can easily share copies of the software files of the data with other users, and also have access to the printers connected to a network, scanners and other peripheral equipment. Thus, advantages of sharing of the equipment and the software compensate the means enclosed in connection of the personal computer.

In a concrete case of the nuclear center of IHEPNP NSC KIPT personal computers are allocated in working rooms on four floors of an industrial building. The total of personal computers included in LICN and workstations makes more than 60. The main lines of each floor represent the separate segments connected through repeaters and concentrators to the common trunk.

The local network of IHEPNP NSC KIPT is constructed on the basis of local networks Ethernet created in divisions and group of the personal computers allocated for collective use incorporated among them and forming the server center. The general structure of an offered network is resulted at the design below.

## EQUIREMENTS OF LICN

Reliable and safe functioning of LICN can be provided only under condition of performance of the following set of the requirements produced on the basis of experience of designing and operation of shared systems and networks of the computers.

## ELECTROSECURITY OF WORKSTATIONS AND SERVERS

The problem consists that a feed of personal computers is carried out usually from the lighting or power electric system of 220 V, thus always there are outflow of a current through circuits of power units of computers (capacity of filters of handicap's, parasitic capacities of transformers and so forth). In result on the case of a computer always probably presence of some voltage which usually is not felt, and even in case of failure of power supplies of a computer of a consequence is limited only to this computer. But when the computer is connected to a local network, through wires of an information network occurrence of electric contact to other computers is possible. In such situation failure on one computer can cause failure of all computers of the whole site of a local network. Besides

because of a potential difference available usually between zero wires of various sites of lighting and power (force) networks work behind such computer can be unsafe for users.

Therefore one of the obligatory requirements to the equipment and structure of a network is maintenance of an electro security. Possible failures of power supplies on any workstation or a server should not cause damages of other workstations or do work at these stations dangerous to the personnel. The best decision is the full electric outcome of units of a network among themselves due to use of networks of radial structure on base so-called twisted pair and refusal of use of networks on the basis of the common trunk on the basis of a coaxial cable. Use as units of a network of concentrators and the routers having optical electronic outcomes; have allowed achieving a comprehensible level of an electro security and reliability of LICN.

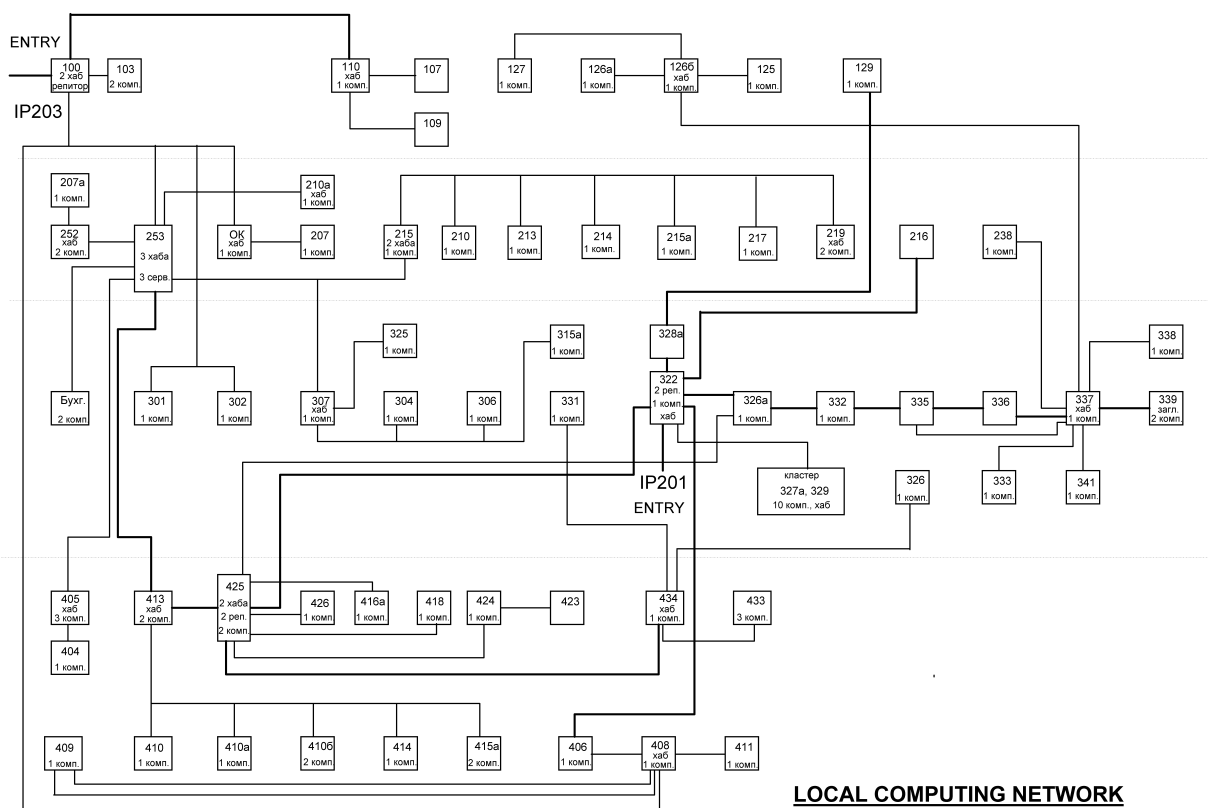

**LOCAL COMPUTING NETWORK**

### MAINTENANCE OF RELIABILITY OF FUNCTIONING OF A LOCAL NETWORK

During work of LICN as frequent enough phenomenon failures in work of separate workstations are. It is connected as to malfunctions of the equipment of a local network (network adapters in computers, infringements of contact in sockets of a network, breaks of conductors in information cables), and with the various casual reasons. Similar possible infringements in work of separate workstations or even local subnets should not cause failures in work of a network as a whole. Use of radial network structure allows minimizing consequences of infringement in work of a network and facilitates diagnostics and detection of the reason of such infringements.

### CONTROLLABILITY OF A NETWORK

The architecture of a network should allow organizing both the centralized management of a network, and division of powers on management and decentralized support of separate sites of a network and local subnets. Such opportunities can be achieved due to use of hierarchical structure of a network and concentrators with an opportunity of routing of information packages. Computers - units of subnet are connected to such concentrator, and as localization of the traffic (information streams between computers of subnet become isolated through the concentrator and do not load other sites of a network), and increase of reliability (in a case practically any malfunctions in work of a network trouble-free work of a site of a network or subnet is provided) thus is achieved.

## **MAINTENANCE OF MULTIPLATFORM AND MULTIPROTOCOL WORK IN A NETWORK**

The great value has also maintenance with multi-protocol work in a network - support of simultaneous work in a network of the workstations using various reports of an exchange (TCP/IP, IPX, NetBIOS), and support of workstations of various types and various operational systems. Use as transport report Ethernet ensures the functioning into these most widespread reports that allows to support work in a network of stations on the basis of processors Intel, DEC, SUN and operational systems MS DOS, Windows, WIN NT, Windows 2000, UNIX (Linux).

Besides the structure of a local network provides an opportunity of connection of workstations to the telecommunication center – ground station of a satellite communication and an output in global network Internet.

## **CONCLUSIONS**

The shared system described in the given work on the basis of the personal computer is created and used for a number of years in server center of IHEPNP NSC KIPT.

Operating experience within several years of such system has shown sufficient efficiency and a demand of services given by it. Besides it is possible to see, that reliable work of system and safety of the user data is provided at a sufficient level in spite of the fact that usual personal computers used as hardware platforms have a level of reliability not above the average, and as the basic operational system OS Microsoft Windows-2000 is used.

## **REFERENCE**

1. V. Stolins. Operating systems. The internal device and designing, 4. M: The Publishing house "Williams", 2002, 848 p.

## **СОЗДАНИЕ И РАЗВИТИЕ ЛОКАЛЬНОЙ ИНФОРМАЦИОННОЙ ВЫЧИСЛИТЕЛЬНОЙ СЕТИ ИНСТИТУТА ФИЗИКИ ВЫСОКИХ ЭНЕРГИЙ И ЯДЕРНОЙ ФИЗИКИ ННЦ ХФТИ**

*В.А. Дудник, Е.В. Криворуков, В.И. Кудрявцев, Т.М. Серета, С.А. Ус, М.В. Шестаков*

Представлены результаты и основные этапы создания и развития локальной информационной вычислительной сети Института физики высоких энергий и ядерной физики ННЦ ХФТИ за последние пять лет. Целью работы было повышение эффективности работы исследователей за счет рационального использования ресурсов и создание на базе локальной информационной вычислительной сети системы коллективного пользования. В статье описывается накопленный опыт и специфика реализации таких систем.

## **СТВОРЕННЯ І РОЗВИТОК ЛОКАЛЬНОЇ ІНФОРМАЦІЙНОЇ ОБЧИСЛЮВАЛЬНОЇ МЕРЕЖІ ІНСТИТУТУ ФІЗИКИ ВИСОКИХ ЕНЕРГІЙ І ЯДЕРНОЇ ФІЗИКИ ННЦ ХФТІ**

*В.О. Дудник, Є.В. Криворуков, В.І. Кудрявцев, Т.М. Серета, С.А. Ус, М.В. Шестаков*

Представлено результати й основні етапи створення і розвитку локальної інформаційної обчислювальної мережі Інституту фізики високих енергій і ядерної фізики ННЦ ХФТІ за останні п'ять років. Метою роботи було підвищення ефективності праці дослідників за рахунок раціонального використання ресурсів і створення на базі локальної інформаційної обчислювальної мережі системи колективного користування. У статті описано накопичений досвід і специфіка реалізації таких систем.