

# EXPERIMENTAL MODEL OF MULTIDETECTOR DEVICE BASED ON CdZnTe DETECTORS

V.G. Batiy<sup>1</sup>, A.N. Nenakhov<sup>1</sup>, A.A. Pravdiviy<sup>1</sup>,  
N.A. Kochnev<sup>2</sup>, V.V. Selyukova<sup>2</sup>, M.A. Khazhmuradov<sup>2</sup>

<sup>1</sup>Institute for Safety Problems of Nuclear Power Plants, Chernobyl, Ukraine  
e-mail: oitp@mntc.org.ua

<sup>2</sup>National Science Center "Kharkov Institute of Physics and Technology", Kharkov, Ukraine  
e-mail: khazhm@kipt.kharkov.ua

The multidetector device for measurement of angular distributions of intensity of gamma - radiation is described. Results of tests of experimental model of device are presented and prospects of use of such device are shown.

PACS: 28.41Te

## 1. INTRODUCTION

The main factor of hazard effect to staff during works on "Shelter" object is external gamma-radiation [1-2]. So for correct calculations of individual dose and shielding optimization it is necessary to know angular distribution of gamma radiation. In this paper angular distribution means dependency of gamma radiation intensity in given point from angles which characterize direction of gamma radiation sources location. The method of shielding optimization, using data about angular distribution of gamma radiation intensity was described in [3].

The method for angular distribution measuring has been developed in ISP NPP [4,5] and ShD-1 device on the base of thermoluminescent detectors (TLD) has been made [6]. This method has been used during pre-project investigations for "Shelter" object stabilization [7-8]. The results of these investigations have been used for shielding optimization on stabilization project developing. Now this method is actively used for measuring at "Shelter" object.

During use of this method we have found some disadvantages, which are connected with detectors type:

- Low sensitivity of TLD (for measuring with satisfactory accuracy it is necessary to irradiate the device with doze approximately 1 Rad, In radiation

conditions of "Shelter" object local zone [8] it means that expose duration must be several days;

- Complexity of preparation of ShD-1 device to next measuring;
- Complexity of digitalization of measured data (the device includes 108 TLD, data extraction takes from 3 to 5 hours, for future processing data are entered to computer manually);
- Impossibility of remote control under measuring;
- Impossibility of control of dynamics of doze rate angular distribution.

For this reason we decided to develop the new device ShD-3 for measuring angular distribution of gamma radiation on the base of detectors with electronic type of data receiving. In this paper the working model of this device is described.

## 2. DETECTOR TYPE SELECTION

Due to good optimization of detector block of ShD-1 (Fig. 1) in the case of such parameters as attenuation factor, angular resolution, mass, detector arrangement, its ball-shaped body was taken as a body for experimental sample. For choosing the detectors we decided to take into account available device scheme (Fig. 2).

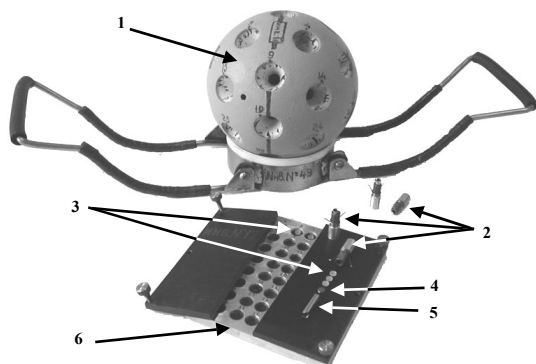

**Fig. 1.** ShD-1 device: 1 – leaden body with collimating apertures; 2 – capsules with detectors; 3 – thermoluminescent detectors; 4 – copper filters; 5 – holders; 6 – table for putting detectors to capsules

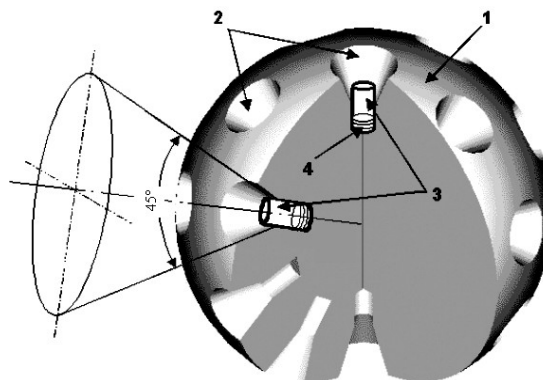

**Fig. 2.** Scheme of ShD-1 device body: 1 – leaden body; 2 – collimating apertures; 3 – capsules with detectors; 4 – thermoluminescent detectors

The analysis of the most commonly used detectors have been done:

Gas discharge detectors. They have low efficiency and don't match due to length. For ensuring of the sufficient attenuation factor on the ShD-1 it is necessary to increase the body size. But in this case it will be possible to move the device only with the help of mechanical device. Besides such detector can't be considered as a point detector. So angular distribution of the device will get worse.

Scintillation detectors. The necessity to use light-reflectors in the scintillation detector and light-transformers (photoelectric multiplier or photodiode) renders impossible the creating of acceptable scintillation detectors blocks. Besides light-reflectors and light-transformers will distort gamma field which is detected by thy device.

Ge and Ge(Li) detectors. The necessity of liquid nitrogen cooling and relatively big size of preamplifiers render impossible to use of such detectors in described multi-detectors device.

CdZnTe detectors. High sensitivity, little size and wide dynamic diapason make these detectors the most perspective for use.

### 3. SCHEME AND FACILITIES OF THE EXPERIMENTAL DEVICE

At present time modernization of ShD-1 device is carried out. We use CdZnTe detectors and electronic scheme for data receiving, keeping and processing, and for control under measuring.

Crystal size is 6×6×3 mm – in this case a aluminum capsule with detector is put into aperture of ShD-1 body (Fig. 1,2).

The Fig. 3 shows scheme of one detector channel. Every channel is completely interchangeable and identical to others. Common scheme of the experimental device is shown on Fig. 4. Principal scheme of preprocessing and data storage is shown on Fig. 5.

Preamplifier – former receives an impulse from detector, reinforces it. Output impulse has negative direction and 10 microseconds duration. Impulse form is near to Gauss distribution.

Comparator-discriminator, counter micro-controller, micro-scheme of nonvolatile memory and voltage stabilizer are located on a separate card.

Comparator-discriminator receives impulse from preamplifier and forms a logical level impulse. Discrimination level is adjusted for every detector channel separately and is set on the level corresponding <sup>241</sup>Am (59.6 keV).

Micro-controller 12C508A (Microchip) has been programmed by specially developed program. Stored data transition is realized by double-wire interface I<sup>2</sup>C at 50 kbps speed. Response time for external control commands (i.e. accuracy of time interval setting) – no more then 10 μs.

Now as a micro-scheme of nonvolatile memory is used 24C16 (Atmel). Memory – 2 kB. This limits possibilities to increase number of stored impulses (measuring cycles).

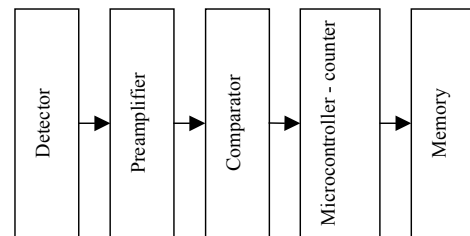

Fig. 3. Block-scheme of one channel of the experimental device

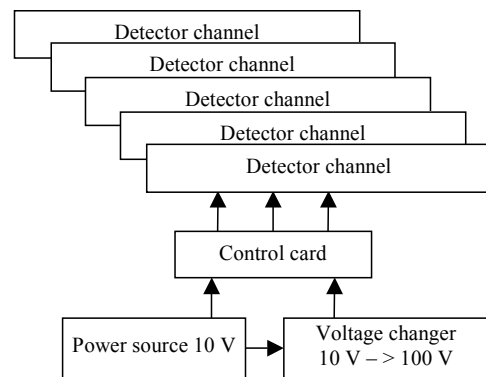
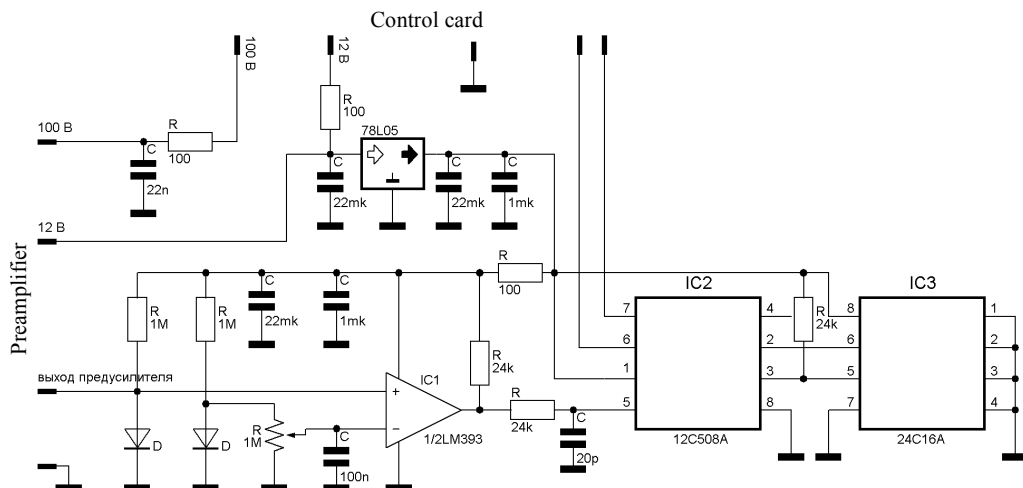

Fig. 4. Common scheme of the experimental device



**Fig. 5. Principal scheme of preprocessing and data storage**

Measured data that are stored in memory, due to NVRAM-programmer are transported to the computer where a final processing is carried out.

Intermediate data registration is carried out for such reasons:

- a) For increasing of reliability and measuring accuracy;
- b) For having control under possible strays during field works near different accidental sources;
- c) For checking hypothesis about normal distribution;
- d) For study of dynamics of registration efficiency under different periodical external forces (in this model every 8 sec).

Memory chip limits time of one measuring cycle by 2.5 hour.

The photo of basic elements of ShD-3 device is shown on Fig. 6.

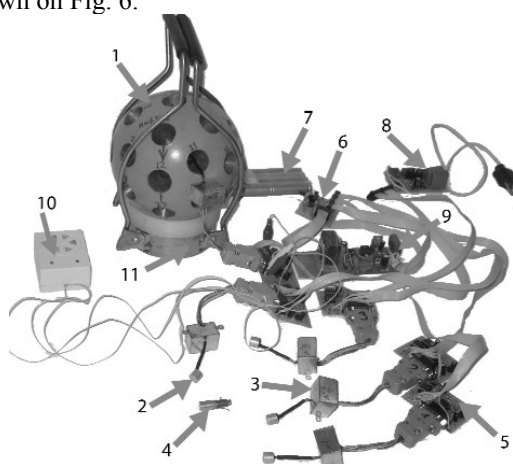

**Fig. 6. Experimental model of ShD-3 device:** 1 – leaden body with collimating apertures; 2 – capsules with detectors; 3 – preamplifier; 4 – capsules with TLD (ShD-1); 5 – preparation card; 6 – control card; 7 – power source 10 V; 8 – charger; 9 – voltage changer; 10 – beep annunciator; 11 – leg

As a charger we use eight of NiCd accumulators. Voltage 10 V, capacity 1 A\*h. It is enough for off-line operation during 10 hours. A special charger for these accumulators has been made.

Changer from 10 V to 100 V (for detectors power supply) provides stabilized output voltage at the decreasing of input voltage to 8 V. Output current – up to 10 mA.

Control chip was made in the form of cross-chip. The detectors and power source are connected to it. On this chip are situated:

- Micro-controller 12C508A. It produces control impulses for countable micro-controllers;
- Voltage monitors 10 V and 100 V with leds indication;
- Interference protection.

For usability of debugging and control under measuring process a little indicated block with sound and leds indication of impulses availability has been created.

Measuring data are stored into programmable memory (NVRAM). Then these data transported to a computer with the help of the programmer. The computer makes the final data processing for ShD-3.

Programmer PonyProg with program application (<http://www.LancOS.com>) is used for reading from nonvolatile memory and for preparing it for the next measuring cycle.

For data preprocessing a special computational program detector.xls (Visual Basic) has been developed. The use of notebook gives possibility to read information and to control measuring results on-line, not only in a laboratory but in field condition.

#### 4. TEST MEASUREMENTS

The calibration measuring of sensitivity to static and variable electric and magnetic fields, to temperature has been carried out in certified laboratory.

During all measuring seances the malfunction of the device haven't happened. Significant changes in electric and magnetic fields haven't caused changes in device characteristics.

Insignificant reduction of registration efficiency (up to 20 %) has been observed when the temperature decreases below 10° C (Fig. 7). However, this effect is equal for all examined detectors and we can expect that it will not have effect to angular distribution measuring. Nevertheless, we are going to set up a heat-sensing device and to fix one more additional parameter for each measuring.

Intermediate results (in 8 sec) allow to do a statistic analysis and to control the dynamics of doze rate changing. Fig. 8 shows time-dependence of report number for one of detectors. During measuring we fixed doze rate in a place where detector was situated.

As a whole experimental results correspond to normal distribution (Fig. 9). Statistic analysis shows that significance level is equal to 5%.

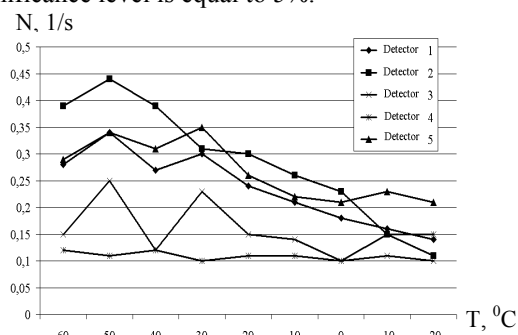

**Fig. 7. Detection efficiency vs temperature**

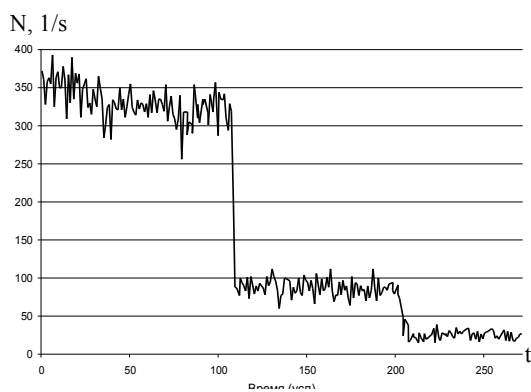

**Fig. 8.** Detection efficiency vs time

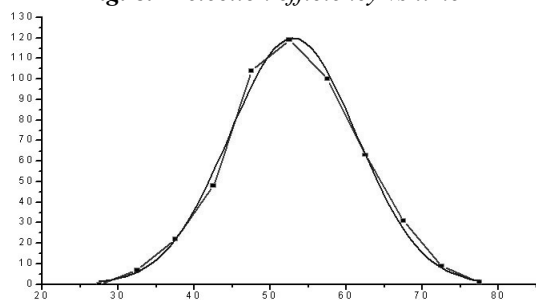

**Fig. 9.** Comparison of ShD-3 results (points) and normal distribution (smooth curve)

It is necessary to point out that sensitivity of ShD-3 will be approximately 1000 times more than ShD-1 sensitivity. Taking into account possibility to automate measuring process, an area of ShD-3 application not only on “Shelter” object but also on any active nuclear objects will essentially extend.

## 5. CONCLUSION

Test measuring of experimental sample of ShD-3 showed that CdZnTe detectors are perspective for creating mobile autonomy multi-detector device for measuring of angular distribution of gamma radiation.

The device characteristics don't change under variable electric and magnetic fields impact. It was observed little decreasing of efficiency of gamma radiation registration under environment temperature decreasing. This effect could be easily taken into account by adding a heat-sensing device or by considering the temperature data.

The measuring results show that this system can be taken as a base system for pre-production model. But it is necessary to make some improvements for cycloinverter efficiency factor increasing (in this model it is a main source of power consumption), simplification of the procedure of data transition to computer (now each channel has its own memory),

reduce scheme size. Particularly it is rationally to develop single card – comparator + micro-controller on the base of SMD components to combine it with preamplifier.

Investigations showed that ShD-3 device is perspective for solving different problems, which are connected with measuring of radiation environment in difficult conditions, for finding of gamma radiation sources, for controlling under source moving.

## REFERENCES

1. A.M. Aljoshin, V.G. Batiy, V.N. Glukhen'kiy et.al. The safety analysis of realization of the Stabilization of beams B1/B2 supports project // *Problems of Chernobyl*. Chernobyl, 2000, v. 6, p. 25.
2. A.M. Aljoshin, V.G. Batiy, V.V. Derengovskiy et.al. Radiation safety analysis during stabilization activities at “Ukryttia” object // *Problems of Chernobyl*. Chernobyl, 2001, v. 7, p. 65.
3. V.G. Batiy, V.V. Yegorov, Yu.A. Zakrevskiy et.al. Biological shield optimization using experimental data on angular distributions of gamma-radiation intensity // *Problems of Chernobyl*. Chernobyl, 2002, v. 9, p. 53-55.
4. V.G. Batiy, V.V. Yegorov, O.O. Kluchnikov et.al. Procedure for measurement of angular distributions of gamma-radiation intensity / MPK7 G01T 1/28. Patent for an invention №51989 of 15.07.2004. Ukraine, bulletin “Industrial property”, №7, 15.07.04.
5. V.G. Batiy, V.V. Yegorov, N.A. Kochnev et.al. Procedure for angular distributions estimation of gamma-radiation exposure dose rate in ukryttia's work performance areas // *Problems of Chernobyl*. Chernobyl, 2002, v. 9, p. 47-52.
6. V.G. Batiy, V.V. Yegorov, Yu.A. Zakrevskiy et al. Device for measurement of angular distributions of gamma-radiation intensity / MPK 7 G01T 1/28. Patent for an invention №51987 of 15.07.2004. Ukraine, bulletin “Industrial property”, №7, 15.07.04.
7. A.M. Aljoshin, V.G. Batiy, V.V. Yegorov et.al. Measurement of angular distributions of intensity of gamma radiation in the zones of works on “Shelter” stabilization: Preprint 02-1 of Interdisciplinary Scientific and Technical Center “Shelter”. Chernobyl, 2002, 47 p.
8. V.G. Batiy, V.V. Yegorov, Yu.A. Zakrevskiy et al. Gamma radiation angular distributions in local zone // *Problems of Chernobyl*. Chernobyl, 2004, v. 15, p. 65-71.

## ЭКСПЕРИМЕНТАЛЬНЫЙ ОБРАЗЕЦ МНОГОДЕТЕКТОРНОЙ УСТАНОВКИ НА ОСНОВЕ CdZnTe-ДЕТЕКТОРОВ

*В.Г. Батий, А.Н. Ненахов, А.А. Правдивый, Н.А. Кочнев, В.В. Селюкова, М.А. Хажмурадов*

Описана многодетекторная установка для измерения угловых распределений интенсивности гамма-излучения. Приведены результаты испытаний опытной модели установки и показаны перспективы использования такой установки.

**ЕКСПЕРИМЕНТАЛЬНИЙ ЗРАЗОК БАГАТОДЕТЕКТОРНОЇ УСТАНОВКИ НА ОСНОВІ  
CdZnTe -ДЕТЕКТОРІВ**

*В.Г. Батій, О.М. Нєнахов, О.А. Правдивий, М.О. Кочєв, В.В. Сєлюкова. М.А. Хажмурадєв*

Описано багатодетекторну установку для вимірювання кутових розподілів інтенсивності гамма-випромінювання. Приведено результати випробувань дослідної моделі установки і показано перспективи використання такої установки.