

ABOUT CREATION OF A TECHNOLOGICAL TOMOGRAPH USING THE ELIAS ACCELERATOR

Yu.M. Arkatov, S.N. Afanas'yev, P.V. Sorokin

*National Science Center "Kharkov Institute of Physics and Technology", Kharkov, Ukraine
e-mail: afanserg@kipt.kharkov.ua*

Estimates were made for the possibility of creating a technological tomograph based on the registration of Compton scattering of photons through the use of the Van de Graaff accelerator (ELIAS) at NSC KIPT. The GEANT3 package was used to simulate the process of production of a sharply directed bremsstrahlung beam, to define the converter thickness, and to determine the angular distribution and energy spectrum of photons. The computation of counting rate for the tomograph's detector has shown that for materials of a density up to 3 g/cm³ the counting rate can reach 2600 counts/sec, this being quite sufficient for tomographs of this type.

PACS: 07.85+n

1. INTRODUCTION

The technological tomograph based on the registration of Compton backscattering of photons falls into a class of devices intended for non-destructive contactless examination or control of various materials, products, equipment, etc.

By the present time, the devices of this type have already been created or are under development at several laboratories of the world [1-4].

For sources of γ -quanta, they use ⁶⁰Co gamma sources with an intensity of radiation from 5 Ci to 370 Ci [1,3], 300 mCi ¹³⁷Cs sources [4], as well as X-ray tubes with a voltage up to 320 kV, and electron accelerators [2]. NaJ crystals are generally used as detectors of scattered photons.

The measurements of substance density by this method offer the possibility of performing a wide range of investigations involving the detection of defects inside a homogeneous material, the determination of the coating quality and the joints of different materials; the measurement of the wall thicknesses of various vessels, the inside of which is inaccessible; the density determination of products produced by powder metallurgy methods, etc.

2. TOMOGRAPHY BASED ON THE COMPTON SCATTERING OF PHOTONS

Physically, the tomograph operation relies on the fact that in the first approximation the photon yield from the Compton scattering is proportional to the density of substance, in which the scattering occurs.

The differential cross section for the Compton scattering is described by the following formula:

$$\frac{d\sigma}{d\Omega} = \frac{r_e^2 (1 + \cos^2\theta)}{2[1 + \gamma(1 - \cos\theta)]^2} \times \left\{ 1 + \frac{\gamma^2 (1 - \cos\theta)^2}{(1 + \cos^2\theta) \cdot [1 + \gamma(1 - \cos\theta)]} \right\}, \quad (1)$$

where r_e is the classical electron radius, $\gamma = E_\gamma/m_0c^2$, θ is the photon scattering angle in the lab. system.

The scattered photon energy is calculated from the formula

$$E'_\gamma = \frac{E_\gamma}{1 + \gamma(1 - \cos\theta)}. \quad (2)$$

The angular dependence of the cross section has its minimum at a scattering angle of 90° for photon energies below 1 MeV. The energy of scattered photons shows a very weak angular dependence in a wide angular range from 60° to 180°.

The schematic diagram of the tomograph is presented in Fig. 1.

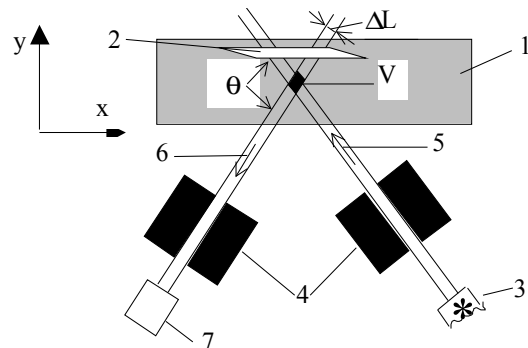

Fig. 1. Schematic diagram of the Compton scattering tomograph. 1-object under study; 2-defect; 3-photon source; 4-collimators; 5-primary γ -beam; 6-scattered γ -beam; 7-detector; θ -scattering angle; V-"investigation volume"; ΔL -interaction length

Two collimators (input and output collimators) specify "investigation volume", which can scan the sample by moving the latter along the x-, y-, z-directions with the help of the positioning table. The number of photons scattered in the direction of the detector is given by the following formula

$$n_{det} = (d\sigma/d\Omega) n_e \Delta L N_\gamma \Delta\Omega_{det} \exp(-(\mu_1 x_1 + \mu_2 x_2)), \quad (3)$$

where N_γ is the number of gamma-quanta coming to the "investigation volume" V from the source through the

beam collimator; ΔL is the interaction length determined by the collimator size of the detector; $\Delta\Omega_d$ is the solid angle determined by the detector's collimator; $(d\sigma/d\Omega)$ is the differential Compton scattering cross section; μ_1 and μ_2 are the linear coefficients of photon absorption before and after scattering, respectively; x_1 and x_2 represent the path passed by the photon in the substance before and after scattering, respectively; and n_e is the electron density given by

$$n_e = \rho_A N_A Z/A, \quad (4)$$

where ρ_A is the density of the substance under study, N_A is the Avogadro number, Z/A is the ratio of the charge to the atomic number of substance under study, with an accuracy of $\sim 10\%$, equal to 0.5 for the elements of the periodic table having $Z < 50$.

Therefore, we have:

$$n_{det.} \approx 0,5(d\sigma/d\Omega)\rho_A N_A \Delta L N_e \Delta\Omega_d \exp(-\mu_1 x_1 + \mu_2 x_2) \quad (5)$$

It is clear that the number of detected photons is specified by the Compton scattering cross section value and is linearly dependent on the scatterer density ρ_A .

3. ESTIMATION OF THE POSSIBILITY OF CREATING THE TOMOGRAPH THROUGH THE USE OF THE ELIAS ACCELERATOR

The present paper considers the possibility of using the accelerated electron beam of the Van de Graaff accelerator (ELIAS) for production of an intense sharply directed γ -quantum beam in order to put the latter to work in the tomograph based on the registration of Compton scattering. The ELIAS accelerator provides an ejected electron beam with an energy of 3 MeV and a current of 100 μA .

The counting rates were calculated by formula (5) for the tomograph's geometry shown in Fig. 2.

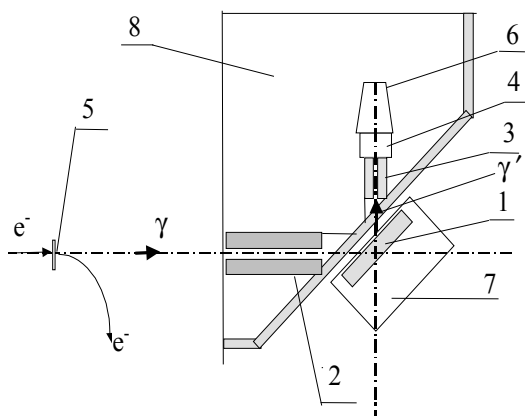

Fig. 2. Schematic of Compton scattering tomograph using the ELIAS accelerator. 1 - object under study; 2 - γ -quantum beam collimator; 3 - detector collimator; 4 - scintillation detector; 5 - converter; 6 - PMT; 7 - positioning table; 8 - detector shield; γ - initial γ -beam; γ' - scattered γ -beam; e^- - electron beam

Since the photon bremsstrahlung spectrum was used, the integration was performed over the spectra of

primary and scattered photons, and the energy dependence of $d\sigma/d\Omega$ as well as of the coefficients μ_1 and μ_2 was also taken into account.

It is assumed that after slowing down in the radiator the electron beam is bent to the beam absorber. The distances from the converter to the scattering point and from the scattering point to the detector are 70 cm and 10 cm, respectively.

All calculations were made in two stages. The first stage included the calculation of the optimum converter thickness in order to produce the highest possible photon yield at slowing down of 3 MeV accelerated electrons in the converter, and the calculation of both the energy spectrum and the angular distribution of photons. These calculations were carried out by the Monte-Carlo simulation using the program GEANT3 [5] with due regard for the absorption and multiple scattering of photons in the converter.

The photon yield was simulated in the direction of electron motion to the solid angle 10^{-4} sterad for Cu and Ta converters. For illustration, Fig. 3 shows the photon yield as a function of Ta converter thickness.

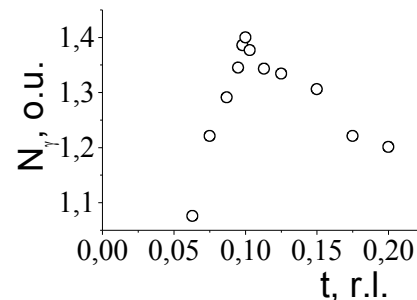

Fig. 3. Photon yield versus Ta converter thickness

The behaviour of photon yield versus thickness for the Cu converter is similar to the Ta converter case shown in Fig. 3. In both cases, the peak of the yield is observed at a thickness value approximately equal to $0.1 X_0$ (X_0 is the radiation unit length equal to 3.8 mm for Ta). However, the yield at the maximum for the Cu converter is 20% lower than the one for the Ta converter.

At the same conditions, the energy spectrum of γ -quanta was also simulated for the Ta converter, 0.1 X_0 in thickness.

The next step was the simulation of the angular distribution of γ -quanta at deceleration of electrons in the 0.1 X_0 thick converter, followed by the calculation of the $dN/d\Omega$ ratio, which was then used to calculate the absolute values of the number of γ -quanta arriving at the "investigation volume". Fig. 4 shows the angular distribution of γ -quanta for the tantalum converter on a per-electron basis.

Based on the results of simulation, it was found that at an accelerated electron energy of 3 MeV and a beam current of 100 μA , $2.5 \cdot 10^8$ γ -quanta/sec will arrive at the sample from the tantalum converter, 0.1 X_0 (0.38 mm) in thickness, through the slit collimator having the $2.5 \cdot 5.0$ mm² aperture (solid angle for the geometry shown in Fig. 2, $\Delta\Omega_b \approx 2 \cdot 10^{-6}$ sterad).

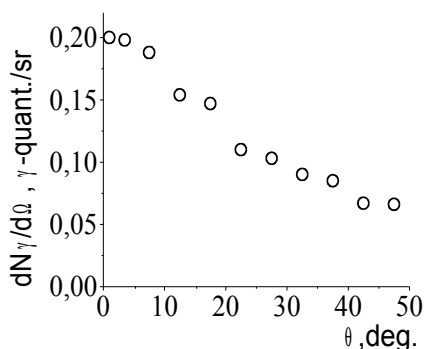

Fig. 4. Angular distribution of photons for the Ta converter

The second stage of the calculation consisted in calculating by formula (5) the quantity of γ -quanta coming to the detector. We used numerical integration with due account for the energy spectra of incident and scattered photons, the energy dependence of absorption coefficients μ_1 and μ_2 , and the energy dependence of the Compton scattering cross section. The scattering angle in the Compton scattering formula was taken to be 90° . The calculations were performed for the cases, where graphite, aluminum or copper were chosen as materials to be studied. The terms x_1 and x_2 in formula (5) were assumed to be the alike and equal to 2, 4 or 6 mm.

The results of calculations are presented in the table. The table lists the values of the counting rate n_{det} , the data-taking time to a statistical accuracy of 0.3% - $t_{0,3}$, and the data-taking time to a statistical accuracy of 1.0% - $t_{1,0}$ for the case, where a "focusing" collimator with 100 slits having the 2.0x2.0 mm² aperture is used as a collimator of the detector. The "investigation volume" for the mentioned collimators of both the detector and the beam will measure 2.5x2.5x5.0 mm³.

Material	x_1, x_2 , mm	n_{det} , count/s	$t_{0,3}$, sec	$t_{1,0}$, sec
¹² C	2	2300	43	4
	4	2100	48	5
	6	1900	53	5
²⁷ Al	2	2600	39	4
	4	2300	43	4
	6	2100	48	5
⁶⁴ Cu	2	400	250	25
	4	20	1300	130

It is evident from the listed values that for graphite and aluminum the expected tomograph compares well with foreign analogs in such parameters as the counting rate and the data-taking time until the statistical accuracy of 0.3% is attained. For copper, these parameters are somewhat worse, though it should be noted that they can be improved by increasing the number of holes in the "focusing" collimator of the detector. Therefore, the high-quality manufacture of the "focusing" collimator is eventually the key moment that

will determine the spatial resolution and the information-taking rate of the device.

Fig. 5 shows the proposed version for the arrangement of the beam shaping channel and the tomograph in the accelerator ELIAS hall.

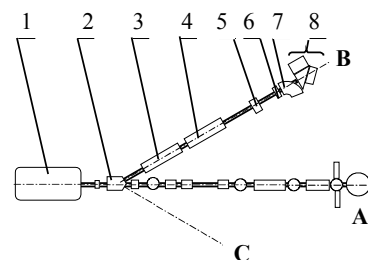

Fig. 5. Arrangement of the tomograph in the ELIAS accelerator. 1-accelerator, 2-bending magnet, 3-beam focusing systems, 4-beam correction systems, 5-current meter, 6-converter, 7-cleaning magnet, 8-tomograph

The arrangement of the accelerator and the existing channel A in the hall will provide, at least, two more channels in the B and C directions, and these new channels can be used not only for tomography, but also for performing other experiments with electron/photon beams.

In conclusion it should be noted that the use of the accelerator instead of very high-activity sources (with the geometry shown in Fig. 2, the counting rates given in Table 1 can be attained by using the sources with activities of $7.6 \cdot 10^4$ Ci for ⁶⁰Co or $6 \cdot 10^4$ Ci for ¹³⁷Cs) appears preferable in some cases, because at off conditions the low-energy accelerator is absolutely safe from the ecology standpoint, and this cannot be said about the sources.

REFERENCES

1. J.A. Stokes, K.R. Alvar, R.L. Corey et al. Some new application of collimated photon scattering for nondestructive examination // *Nucl. Inst. and Meth.* 1982, v 193, p. 261-267.
2. P. Zhu, P. Duvauchelle, G. Peix and D. Babot. X-ray Compton backscattering techniques for process tomography: imaging and characterization of materials // *Meas. Sci. Technol.* 1996, v 7, p. 281-286.
3. Z. Asa'd, M. Asghar and D.C. Imrie. The measurement of the wall thickness of steel sections using Compton backscattering // *Meas. Sci. Technol.* 1997, v. 8, p. 377-385.
4. E.M.A. Hussein and T.M. Whynot. A Compton scattering method for inspecting concrete structures // *Nucl. Inst. and Meth.* 1989, v. A283, p. 100-106.
5. *GEANT 3. Detector description and simulation tool.* CERN program library. 1993.