

DESIGN OF STRAUS-R ACCELERATOR

V.S. Gordeev, G.A. Myskov, E.S. Mikhailov, D.V. Laptev
Russian Federal Nuclear Center – All-Russia Scientific Research
Institute of Experimental Physics (RFNC-VNIIEF)
607188, Sarov, Nizhni Novgorod region, Russia
E-mail: gordeev@expd.vniief.ru

The paper presents a design of the direct-operation high-current electron accelerator STRAUS-R that is a modification of STRAUS-2 now in force. The accelerator is aimed at generating single bremsstrahlung pulses in the mode of electron beam focusing on the target. According to the calculations it should provide for getting the dose (Si) of 0.2÷0.25 Gy at a 1 meter distance from the target, the electron beam current being equal to 50÷60 kA, boundary energy of electrons – to 2.7÷3.0 MeV, bremsstrahlung pulse duration – to ≤ 50 ns and beam diameter on the target – to ≤ 5 mm. The description and results of numerical simulation of physics processes taking place in the accelerator are given.

PACS numbers: 29.17.+w

The experiments on electron beam focusing on the STRAUS-2 accelerator [1] have shown the possibility of using the facilities of this type as “point” sources of high-power single bremsstrahlung pulses with the duration of several tens of nanoseconds. Such sources are of interest for a set of applications, in particular, for pulsed X-rays radiography of high-speed processes. In this connection there occurred the necessity of developing and

creating the facility with a relatively “soft” spectrum of bremsstrahlung ($E_{\text{boundary}} \leq 3$ MeV), ~50-ns pulse duration and ~0.2 Gy (Si) dose at 1-meter distance from the target. On the basis of a well-developed in VNIIEF technology of stepped forming lines there was developed the design of such accelerator that was called STRAUS-R. As a prototype of this facility STRAUS-2 accelerator [1-3] was used.

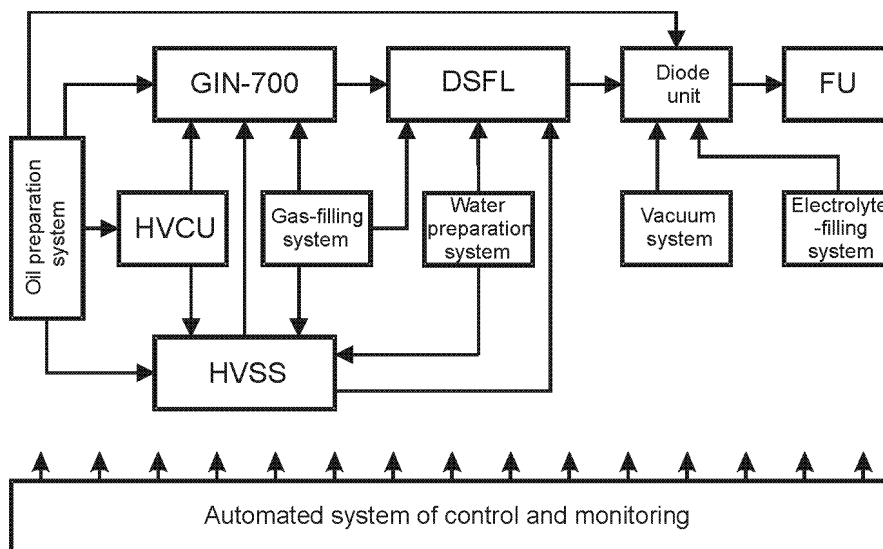

Fig. 1. Structural scheme of STRAUS-R accelerator.

In Fig. 1 there is presented the structural scheme of STRAUS-R accelerator. Into the facility there are incorporated the following constituents:

- generator of pulsed voltage GIN-700,
- high-voltage pulse forming system on the basis of a double stepped forming line (DSFL),
- diode assembly with an output vacuum chamber and a focusing unit (FU),
- high-voltage synchronization system (HVSS),
- automated system of control and monitoring as well as technological and auxiliary systems.

The latter systems includes high-voltage charging units (HVCU), systems of vacuum pumping, gas filling, electrolyte filling, water and oil preparation.

The forming system with the diode and focusing

units whose structural scheme is presented in Fig. 2 is the main functional section of the accelerator. As well as in the STRAUS-2 accelerator the high-voltage pulse forming system is based on DSFL consisting of five sections of homogeneous lines with the following impedances: $Z_1=0.9$ Ohm, $Z_2=0.8$ Ohm, $Z_3=1.9$ Ohm, $Z_4=3.2$ Ohm and $Z_5=18$ Ohm. As differentiated from STRAUS-2 this DSFL possesses the unfolded configuration and the electric length of line sections composing it is longer by a factor of 1.5 ($\tau_0 \approx 30$ ns). The internal volume of DSFL is filled with de-ionized water with ≥ 5 M Ω -cm resistivity used as dielectric substance. To charge DSFL to 600-700 kV voltage there will be used 8-cascade generator GIN-700 made in accord with Arkadiev-Marx scheme (Fig. 3). In each cascade two

capacitors of IEPM-100-0.4 type of $0.4 \mu\text{F}$ capacitance are used. These capacitors have comparatively small dimensions ($225 \times 176 \times 422 \text{ mm}^3$), they possess sufficiently high discharge current ($\leq 100 \text{ kA}$) and low intrinsic inductance ($\leq 50 \text{ nH}$). The GIN-700 capacitance in shock constitutes about 100 nF and it is matched to the DSFL

capacitance (96 nF). The maximum energy store is 32 kJ at the charging voltage of 100 kV . In the first three cascades of the generator there are installed controlled three-electrode discharge switches of trigatron type, while in the others – two-electrode ones operating in the mode of self-breakdown. The elements developed for LIA-30 accelerator [4] are used in GIN-700 design.

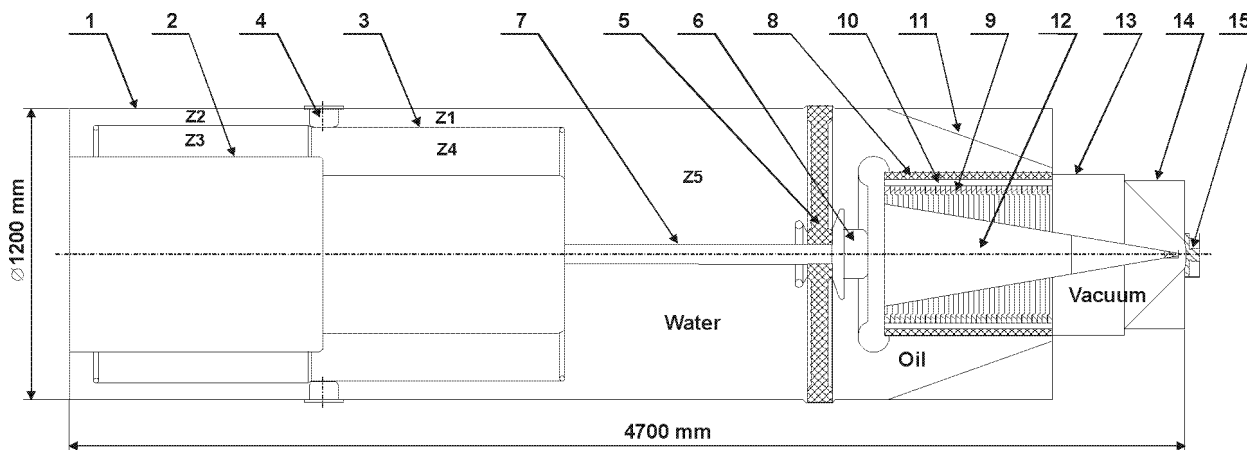
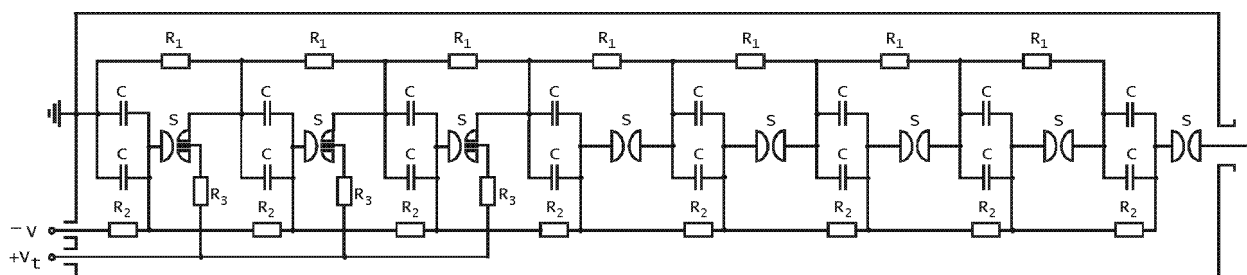

Fig. 2. Structural scheme of STRAUS-R forming system and diode unit.

1 – case; 2 – internal electrode; 3 – high-voltage electrode; 4 – multi-channel switch; 5 – separating diaphragm; 6 – pre-pulse switch; 7 – internal electrode of output line; 8 – dielectric tube; 9 – sectioned insulator; 10 – volume of resistive load; 11 – conical electrode; 12 – cathode holder with a cathode unit; 13 – output vacuum chamber; 14 – focusing unit; 15 – anode flange with a target unit.



R_1, R_2 – resistors of charging circuit ($2 \text{ k}\Omega$), R_3 – resistors of triggering circuit ($100\text{-}300 \Omega$).

Fig. 3. Electrical circuit of GIN-700 generator.

DSFL is switched by 20 controlled spark switches of trigatron type uniformly positioned by the azimuth on the forming system case. To trigger the switches it is supposed to use a modified version of the synchronization pulse generator GIS [5] experimentally proved as a part of synchronization systems of LIA-10M and STRAUS-2 accelerators. The peculiarity of this generator consists in the formation on two cable loads of pulses different by parameters. One of the pulses (amplitude $+60 \text{ kV}$, rise-time $\leq 5 \text{ ns}$) is delivered to the triggering units of the multi-channel discharge switch through 10 KVI-120 cables (one cable / two switches). The other pulse (amplitude $+130 \text{ kV}$, rise-time $\sim 7 \text{ ns}$) is formed on KVI-300 cable and serves to trigger the pre-pulse switch connecting DSFL with the diode unit.

By its design the diode unit is similar to the one used in STRAUS-2 accelerator. The voltage pulse from the output of DSFL is delivered to the diode through the accelerating tube produced on the basis of sectioned insulator 0.6 m in diameter and $\sim 0.65 \text{ m}$ long. It represents a

set of alternate rings of organic glass and stainless steel agglutinated with a special compound. The insulator is placed inside a polyethylene tube and fastened with the aid of rubber diaphragms. The cavity formed in this case between the tube and insulator is filled with electrolyte (water solution of NaCl) serving to align the electric potential along the accelerating tube.

The unit of electron beam focusing was experimentally tested on STRAUS-2 accelerator [1]. It was not supposed to introduce any changes to its design. It is produced on the basis of a converging conical line with self-magnetic insulation. The impedance of the line is $\sim 90 \text{ Ohm}$, its length $\sim 250 \text{ mm}$. The external electrode of the line is located inside a cylindrical case of the focusing unit (fig. 2) and represents a hollow thin-walled conoid of stainless steel with the base diameter equal to 550 mm and $\sim 45^\circ$ half-angle. The internal electrode is a structural continuation of the cathode holder and is attached to the latter through threaded connection. It is made of stainless steel as well and possesses a conical

shape. The cone base diameter is 160 mm, the half-angle is $\sim 10^\circ$. At the electrode end an interchangeable conic cathode header of $\varnothing 15/\varnothing 10$ mm annular edge produced of W-Ni-Fe alloy is installed. A flange of stainless steel 100 mm in diameter with the built-in target unit serves as anode. The accelerating gap constitutes 15 mm in the mode providing for maximal output dose of bremsstrahlung. The target represents a tantalum disk 32 mm in diameter (working part - $\varnothing 20$ mm) and 0.3 mm thick installed in the central hole of the anode flange. The aluminum filter-absorber of electrons 10-20 mm thick is installed behind the target.

This beam-focusing unit is attractive due to the simplicity of its design and absence of additional power supplies. The electron beam formation and its focusing on the target is ensured through the forces of the intrinsic magnetic field of the electron beam.

For the presented configuration of STRAUS-R accelerator there were performed numeric calculations of output electric characteristics. In Fig. 4 there is presented a calculated voltage pulse in the diode. Its shape is close to the trapezoidal and its "flat" top is explicit. Its amplitude is approximately equal to 3 MV, while the duration on half-maximum – to ~ 60 ns. Such pulse shape is ensured at the cut-in of the pre-pulse switch at the beginning of the second (working) half-wave of voltage formed at the output of DSFL 140 ns after the multi-channel switch operation. The pulse shape of the diode current coincides with the voltage pulse shape fully in the concrete, its amplitude constitutes ~ 50 kA.

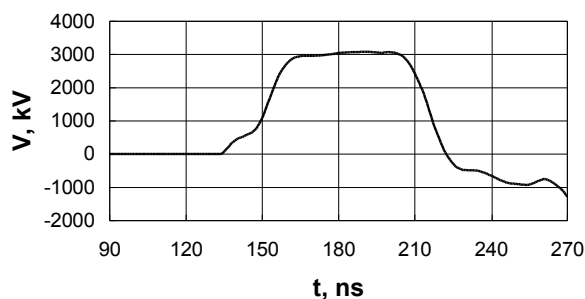

Fig. 4. Calculated diode voltage pulse of STRAUS-R accelerator.

The above-specified parameters make it possible to hope for getting the required bremsstrahlung dose of 0.2-0.25 Gy (Si) at a 1-meter distance from the accelerator target. Basing on the calculations the bremsstrahlung pulse duration should constitute about 50 ns, while the diameter of the focused on the target electron beam – 4-5 mm (at half-maximum of current density distribution over the target).

It should be mentioned that the works in creating STRAUS-R accelerator are progressing quite quickly. By now there have been fully developed the designs of all its systems and assemblies, the required design specifications have been issued. There have been produced at large: GIN-700 generator, high-voltage system of synchronization as well as technological and auxiliary equipment. There have been as well developed and produced the automated system of accelerator control and monitoring. The production of the forming system and diode unit is being completed now. The works on accelerator mounting are scheduled to be performed in the first half of the coming year of 2002 after the experimental hall intended for allocation of the accelerator is constructed.

REFERENCES

1. V.S.Gordeev, G.A.Myskov, V.O.Filippov et al. Investigation of STRAUS-2 Pulsed Electron Accelerator Characteristics // *Problems of Atomic Science and Technology. Issue: Nuclear-Physics Research* (35). 1999, No. 4. p. 71-73.
2. V.S.Bossamykin, V.S.Gordeev, A.I.Pavlovskii et al. STRAUS-2 Electron Pulsed Accelerator // *Proc. 9th IEEE Int. Pulsed Power Conf.*, Albuquerque, NM. 1993, v. 2. p. 910-912.
3. V.S.Bossamykin, V.S.Gordeev, A.I.Pavlovskii et al. Pulsed Power Electron Accelerators with the Forming Systems Based on Stepped Transmission Lines // *Proc. 9th Int. Conf. on High Power Particle Beams (BEAMS-92)*, Washington, DC. 1992, v. 1, p. 505-510.
4. V.S.Bossamykin, A.I.Gerasimov, A.I.Pavlovskii et al. // *PTE*. 1997. No. 2. p. 5.
5. V.S.Bossamykin, V.S.Gordeev, A.I.Pavlovskii et al. Linear induction accelerator LIA-10M // *Proc. 9th IEEE Int. Pulsed Power Conf.*, Albuquerque, NM. 1993, v. 2, p. 905-907.