

A PULSE TRANSFORMER FOR A 10 MW KLYSTRON POWER SUPPLY

*P.A. Bak, I.V. Kazarezov, V.V. Kobets, A.A. Korepanov, G.S. Krainov,
V.I. Radchenko, V.S. Severilo, A.A. Tuvik
Budker Institute of Nuclear Physics, SB RAS,
630090, Novosibirsk, Russia, Lavrentiev Ave., 11
e-mail: I.V.Kazarezov@inp.nsk.su*

The design and test results of the Pulse Transformer (PT) for the klystron with a voltage of 120 kV, klystron current of 130 A and a pulse duration of 1.4 ms is presented. The PT design was realized with taking into account the following requirements: no edge effect on the secondary winding; no overvoltage along the secondary winding at the klystron breakdown; random high voltage breakdowns may occur only between metal parts, not on the windings; the sharp voltage edge applied to the primary winding should not cause a turn-to-turn overvoltage.

PACS number: 29.17.+w

A superconducting linear electron positron collider TESLA at an energy of several hundred GeV with an operating frequency of 1.3 GHz (for powering RF structures) is being presently developed at DESY (Germany). Within the frame of TTF program, the Budker Institute of Nuclear Physics has been conducted R&D on the modulator for power supply of a multibeam klystron with the following output parameters of the klystron voltage pulse [1]:

- Operating voltage 120 kV
- Klystron current 130 A
- The top duration pulse 1.4 ms
- Pulse rise and fall times does not exceed 100 μ s
- Pulse repetition rate is up to 10 Hz.

As a first stage of the R&D it was suggested to carry out the design and manufacture of the pulse transformer (PT) stepping up the modulator pulse from 10 kV up to 120 kV to the klystron with pulse parameters described above.

The development was carried out taking into account a number of conditions as:

- the absence of large inhomogeneities of electric fields (edge effects) in high voltage insulation;
- voltage gradients along the secondary winding in the operating regimes and at breakdowns should not differ too much;
- in the case of high voltage breakdown, the breakdown should proceed only on metal parts but not in windings;
- applying fast rise time of voltage to the primary winding should not cause excessive overvoltages between turns of the primary winding;
- the absence of partial discharges in the high voltage insulation of the secondary winding.

The first condition was realized for the charge of using the symmetric secondary winding with a middle point under high potential;

the second one was met by the use of additional capacitances providing a uniform distribution of the voltage at a breakdown;

the third one was fulfilled with equipping the secondary winding with metal shields and inserting a grounded shield between the primary and the secondary

windings.

the fourth one was realized by placing a capacitance shield on the primary winding. This capacitance shield provides a uniform voltage distribution along the primary winding at the pulse rise time.

the fifth – by impregnating coils of the secondary winding with the epoxy compound according to technology eliminating partial discharges with further electric tests of each coil.

At the design stage, two types of dielectrics as oil or SF-6 gas were considered as a basic insulation. By the order of the customer, the choice was made in favor of the mineral oil.

The schematic diagram of PT is given in Fig. 1. The primary winding of PT is made of four connected in parallel windings (W11, W12, W13, W14) connected between each other in pairs.

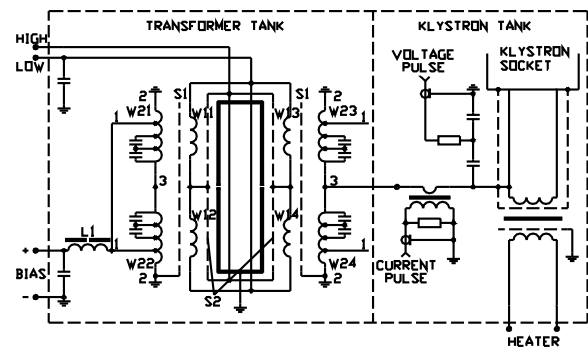

Fig. 1. PT schematic diagram.

In order to decrease the interturn overvoltages, each winding has a shield S2 providing the equalizing of voltage gradients along the winding when applying the voltage pulse with a fast rise or fall time. The PT secondary winding consists also of four windings connected in parallel (W21, W22, W23, W24) and connected in pairs from the high voltage part. Such a connection enables one to eliminate the influence of the edge on the electric strength and thereby to decrease the gap and PT leakage inductance.

Voltage distribution in the high voltage part of the secondary winding is given in Fig. 2. Each secondary winding is made of 15 coils. Shields inside each section of the secondary winding and the grounded shield S1

prevent the breakdown propagation directly between turns of the primary and secondary windings. Though such reinforcing elements on secondary sections result in decreasing the electrical strength of the high voltage gap, it increases the reliability of PT windings.

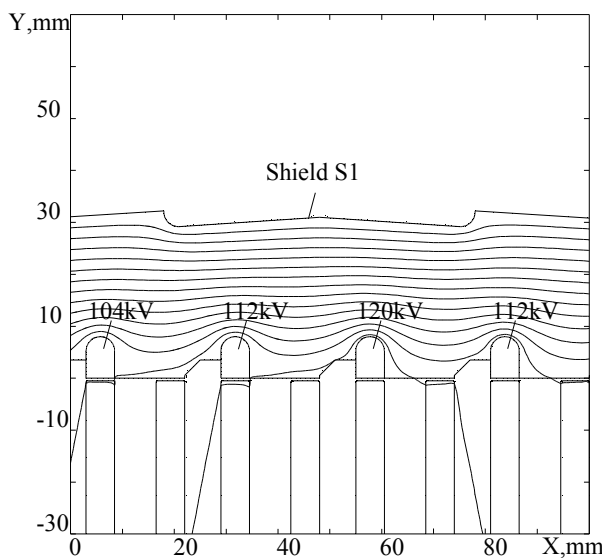

Fig. 2. Electric field equipotentials in PT high voltage gap.

In order to prevent inadmissible overvoltages at sections of the secondary winding at breakdowns of transformer high voltage insulation or at klystron breakdowns, additional capacitances C6d...C15d are installed in parallel to sections (Fig. 3). Fig. 3 shows the equivalent circuit of the secondary winding for a calculation of the voltage distribution process at sections if the breakdown occurs. At the initial moment, voltage is distributed homogeneously along the winding, i.e., the longitudinal capacitances of sections C are equally charged and voltage at transverse capacitances of sections C1t...C15t increases linearly from $U_{max}/15$ up to its maximum value U_{max} .

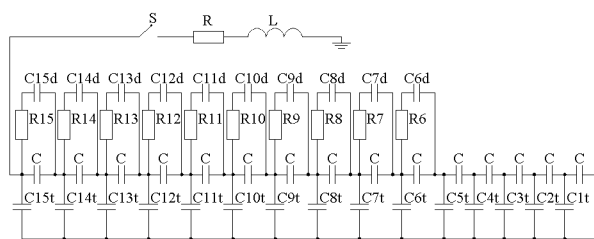

Fig. 3. Capacitive circuit for overvoltage calculation in PT secondary winding.

$C=334 \text{ pF}$, $R=2 \text{ Ohm}$, $L=2 \text{ } \mu\text{Hn}$, $R_{15}=2.5 \text{ Ohm}$,
 $R_{14}=3.3 \text{ Ohm}$, $R_{13}=R_{12}=R_{11}=R_{10}=5 \text{ Ohm}$,
 $R_9=R_8=R_7=R_6=10 \text{ Ohm}$, $C_{15d}=4.8 \text{ nF}$,
 $C_{14d}=4.25 \text{ nF}$, $C_{13d}=3.8 \text{ nF}$, $C_{12d}=3.1 \text{ nF}$,
 $C_{11d}=2.5 \text{ nF}$, $C_{10d}=1.88 \text{ nF}$, $C_{9d}=1.41 \text{ nF}$,
 $C_{8d}=0.94 \text{ nF}$, $C_{7d}=0.55 \text{ nF}$, $C_{6d}=0.22 \text{ nF}$,
 $C_{15t}=43 \text{ pF}$, $C_{14t}=49.3 \text{ pF}$, $C_{13t}=55.5 \text{ pF}$,
 $C_{12t}=61.7 \text{ pF}$, $C_{11t}=67.9 \text{ pF}$, $C_{10t}=74.1 \text{ pF}$,
 $C_{9t}=80.3 \text{ pF}$, $C_{8t}=86.5 \text{ pF}$, $C_{7t}=92.7 \text{ pF}$, $C_{6t}=99 \text{ pF}$,
 $C_{5t}=105.2 \text{ pF}$, $C_{4t}=111.4 \text{ pF}$, $C_{3t}=117.6 \text{ pF}$,
 $C_{2t}=123.8 \text{ pF}$, $C_{1t}=130 \text{ pF}$.

The load breakdown is similar to the closing of the switch S. The choice of shunting capacitances C6d...C15d is determined by the condition of reducing overvoltage at sections of the secondary winding at breakdowns to the value of 1.5. Fig. 4 shows the potential distribution along the secondary winding (lower curve) and overvoltage factor at winding sections with correcting capacitances and without them for the case of $L=0$ (see Fig. 3). An inductance $L=2 \text{ mH}$ is the inductance of the PT-load discharge circuit and an inductance of sections of the secondary winding for capacitive current. This inductance causes the oscillating process of voltage redistribution at sections which causes an increase in overvoltages at above mentioned correcting capacitance up to ~ 1.2 . For damping oscillations at breakdown and for limiting energy released in the arc, correcting capacitors are connected to sections through resistors R6...R15.

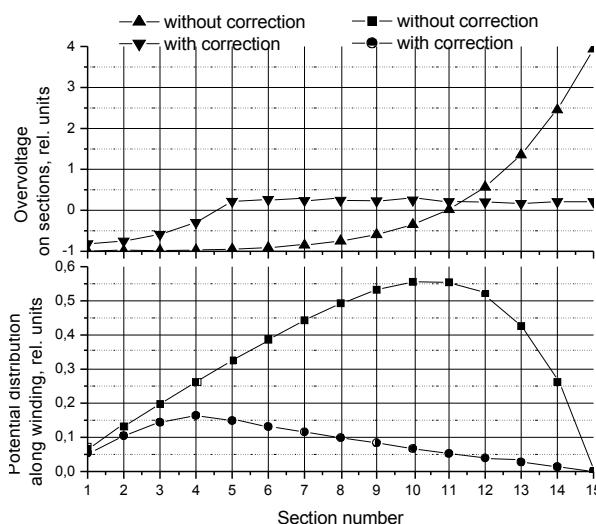

Fig. 4. Potential distribution along the secondary winding and overvoltage factor at sections (with and without correction).

For the efficient use of magnetic core, we introduced its biasing through first sections of the secondary windings connected through the choke L1 to the bias circuit power supply.

PT tank consists of two sections, the transformer and klystron sections (Fig. 5). In the klystron section, there are the klystron itself with high-voltage connector, klystron filament transformer (4) and capacitive divider (6). In order to provide time constant of the transformer current set by technical requirements (pulse top drop at the load of 50 Ohm and duration of 1 ms should not exceed 1%), the transformer core was selected to be the 50NP permalloy.

The design of the transformer is given in Fig. 5. The basic component of PT is a magnetic core made of 8 subcores. Cores with the cross-section of 90x135 mm are wound of the anisotropic steel 3408 with a phosphate insulating cover. In order to remove internal stress and for improving magnetic parameters, prior to impregnating the cores were annealed. After impregnation, cores were cut in halves. Then these halves were glued to each other through spacers into solid unit and then in-

stalled into the casing of stainless steel and fixed there with the epoxy compound. The total cross-section of the magnetic core taking into account the filling factor is 920 cm^2 .

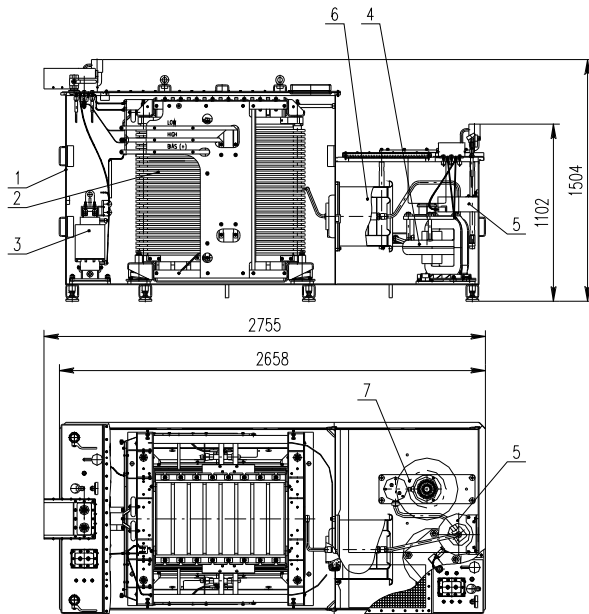

Fig. 5. PT design.

1 – transformer tank, 2 – pulse transformer, 3 – core isolation choke, 4 – filament transformer, 5 – current transformer, 6 – capacitive divider.

The length of the average magnetic line is 2.52 m. The magnetic core weight is 1800 kg.

Primary windings are made of PSD wire with the cross-section of $4 \times 5.6 \text{ mm}$ on the glass reinforced textolite frame of a trapezoidal prism shape. The protection shield is glued on the inner side of the primary winding

frame.

The secondary winding consisting of 4 windings connected in parallel is located and fixed on the lower beam of the magnetic core. The secondary winding is a package of 30 sections assembled between 2 glass reinforced textolite bed plates. The secondary winding section has 48 coils helically wound in two layers by the PETVSD wire of $0.9 \times 5 \text{ mm}$ in cross-section.

The protecting shield made of stainless steel ribbon of 0.5 mm in thickness connected to the coil end is fixed along the inner contour of the lower layer of the coil. The coil together with the shield is impregnated with the epoxy compound.

At present, the manufacture of PT is almost completed and a cycle of tests envisaged by TR has been performed.

The transformer was tested at voltage of 150 kV and also in the regime of short circuit (8 hours at nominal currents of the primary and secondary windings, and bias choke and filament current). Now there is a problem concerning voltage distribution along secondary winding during breakdowns at a voltage more than 150 kV.

The leakage inductance is $L_s = 320 \mu\text{H}$.

Magnetic core parameters were measured. According to measurements in the nominal regime of operation, the total magnetizing current does not exceed 25 A at a bias current of 5 A, that corresponds to TR.

REFERENCES

1. A.Akimov, A.Cherniackin, I.Kazarezov et. al. *Pulse Power Supply System for the 10 MW TESLA Klystron* (Performed under R&D Contract Attachment 5 to Agreement RU/03533872/50095 for DESY, Hamburg).