

STATUS OF RF SYSTEM FOR VEPP-5 DAMPING RING

Ye. Gusev, N. Kot, S. Krutikhin, I. Kuptsov, G. Kurkin, I. Makarov, N. Matyash, L. Mironenko, S. Motygin, V. Osipov, G. Ostreiko, V. Petrov, A. Popov, E. Rotov, I. Sedlyarov, G. Serdobintsev, A. Shteinke, V. Tarnetsky, A. Frolov, K. Chernov, V. Volkov
BINP SB RAS, Novosibirsk, Russia

The paper presents the RF system of VEPP-5 damping ring created at BINP Novosibirsk. The RF system operates at 700 MHz and consists of the generator based on KU-393 klystron, transmitting waveguide with wave-to-coax adapters, accelerating cavity, and control system. HOM cavities are damped with resistive loads to eliminate the beam instability. Parameters and results of cold measurement tests and high power level tests are presented.

PACS: 29.20.-c

1. INTRODUCTION

The damping ring is designed to store and cool 510 MeV electron and positron bunches with number of particles of $2 \cdot 10^{10}$ [1]. The preinjector is a 510 MeV linac (operating at 2856 MHz). RF system parameters are defined by the requirements to obtain short and high power bunches in the damping ring. It is achieved by choosing large accelerating voltage amplitude and high RF ratio – 700 MHz that corresponds to the 64-th harmonics of the particle revolution frequency. RF system block diagram is shown in Fig.1. It consists of the RF generator, circulator, waveguide section, RF cavity, and control system.

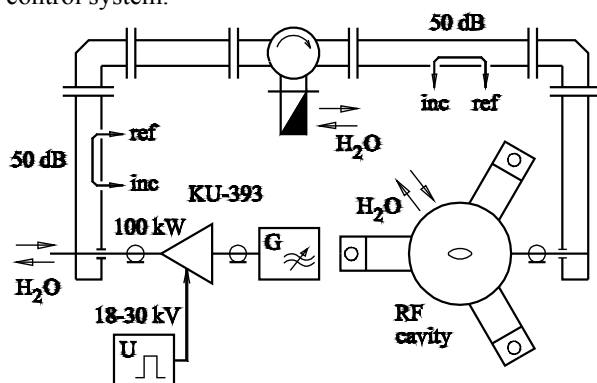

Fig.1. RF system block diagram

2. RF GENERATOR AND WAVEGUIDE SECTION

100 kW klystron KU-393 serves as the RF power source. Obtained parameters of klystron generator are listed in Table 1.

Table 1: RF generator parameters

Frequency, MHz	700
Voltage, kV	27
Beam current, A	5.4
Output power, kW	65
Efficiency, %	45
Gain, dB	46

The klystron is fed from a 200 kW six-phase rectifier. The voltage is controlled by thyristors. A resistor is inserted into the circuit to prevent the klystron damage during discharges. The klystron solenoid consists of five coils; each of them is fed from a separate source.

RF power is transmitted through the aluminium rectangular waveguide (292.1×146.05 mm). The waveguide

attenuation is 0.0035 dB/m. The klystron and cavity are connected to the waveguide via wave-to-coax connectors with VSWR less than 1.05 at the operating frequency. The feedthrough power is measured with directional couplers. The Y-circulator is installed into the waveguide section to uncouple the klystron from the cavity. Y-circulator design parameters are listed in Table 2.

Table 2: Circulator parameters

Feedthrough power, kW	100
Loss power, dB	0.3
Input VSWR	<1.2
Dissipated power, kW	<15

3. RF CAVITY

A cylindrical copper cavity with small protrusions in the aperture area is made by brazing the discs to the sidewall. At present, the cavity is installed into the damping ring (Fig.2).

RF power is transmitted to the cavity through 75-Ohm coaxial feeder. At the operating frequency, VSWR of the wave-to-coax adapter is better than 1.15. The inductive power input is used. A cylindrical window made of 22XC ceramics isolates the cavity vacuum volume from the atmosphere. The frequency is tuned by the contact-free plunger. The cavity walls and plunger are cooled by water. Power input and plunger vacuum parts are coated with TiN to suppress the RF discharge.

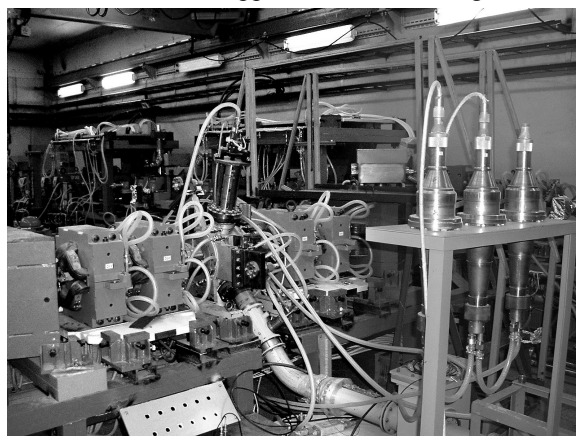

Fig.2. RF cavity in the damping ring

The HOM cavities were heavily loaded to provide phase stability of short bunches in the ring. Coupling with HOMs is provided by three waveguides, uniformly azimuthally distributed, with cutoff frequency of

908 MHz. HOMs' energy are distributed via wave-to-coax adapters into these waveguides and then to the external loads. Within the range 0.95...2.2 GHz, VSWR of the adapters is less than 2 and measured Q-factors of the majority of HOMs do not exceed 100. Q-factor of the operating mode E_{010} decreased by 7.5% during connection of the loads. The main cavity parameters are listed in Table 3. RF system elements are also described in [2,3].

Table 3: RF cavity parameters

Operating frequency, MHz	700
Shunt impedance, MOhm	4
Q-factor	2000
Transit time factor	0.748
Accelerating voltage, kV	200
Frequency tuning, MHz	1.6

4. CONTROL SYSTEM

A simplified block-diagram of the RF system is shown in Fig.3. The Master Oscillator is a source of reference signals and the driver signal for the RF power amplifier.

There is a feedback loop to control the RF voltage amplitude at the cavity gap. RF signal V_{cav} from the cavity sampling loop comes to the amplitude detector of the Modulator. Output of the amplitude detector is connected to a differential amplifier. The other input of the amplifier has a signal of DC voltage from DAC controlled by a computer. Output signal from the differential amplifier controls the Gain Control stage of the RF power amplifier. Gain of the differential amplifier is large enough, so the cavity gap voltage is kept proportional to the signal from DAC.

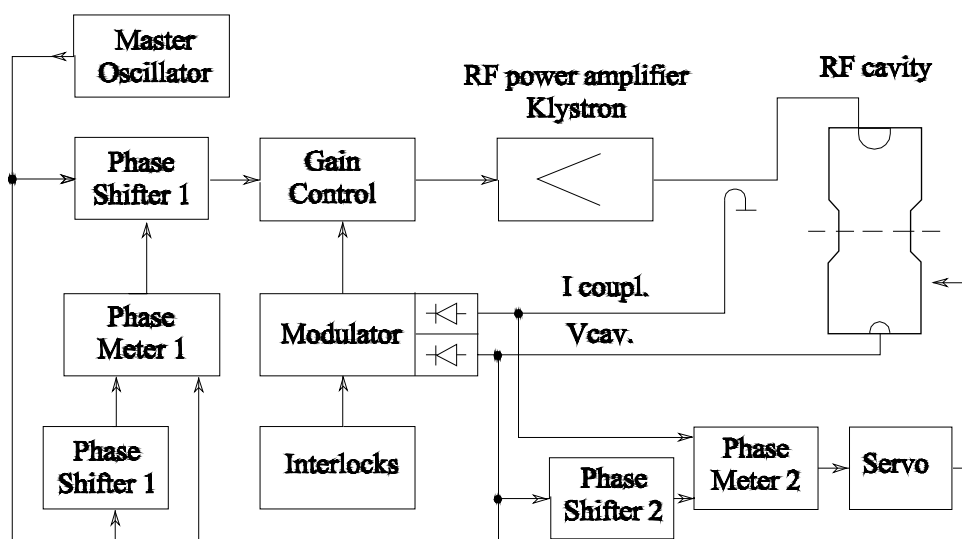

Fig.3. RF control system block diagram

The other feedback loop controls the phase of the RF cavity voltage in relation to the reference signal of the Master Oscillator. Phase difference between signals V_{cav} and that of the reference signal is measured by the Phase Meter 1. Output signal of the Phase Meter controls the electronic Phase Shifter 1 installed into the RF power amplifier channel. It is possible to set initially the cavity voltage phase with the Phase Shifter 2.

The time constant of the two feedback loops is about 300 seconds and the amplitude and phase modulation index of the RF cavity voltage is less than $2 \cdot 10^{-3}$.

The frequency of the RF cavity fundamental mode should be constantly tuned to the resonance to compensate the cavity temperature alterations due to changes in the cooling water temperature or operating regime. The Phase Meter 2 measures the phase difference between the RF signal V_{cav} and the signal I_{coup} which is proportional to the current in the RF cavity coupling loop. The Phase Meter output signal drives the tuner mechanism through the Servo amplifier. Time constant of the feedback loop is about 200 msec, the tuning error is less than 5° .

The Interlock module switches off the Modulator in emergency condition. The driver RF signal for the klystron is removed in this case. Control and monitoring of the RF system from computer are made through the CANBUS serial network.

5. RESULTS OF RF SYSTEM TESTS

RF system tests were carried out in three stages. Firstly, the klystron generator was connected to the matched watercooled load via the waveguide section. The maximal power of 65 kW has been obtained in a continuous regime.

At the second stage, the cavity was assembled, heated for 24 hours at 150°C at the stand, and connected to the waveguide. Without RF power, the ion pump of 160 l/s productivity provided 10^{-9} torr vacuum. RF conditioning was started in the pulsed mode. This mode limited the discharge energy and allowed the pressure to be maintained at the required level (10^{-9} torr) by varying the off-duty factor. After that, the conditioning were carried out in continuous regime; the voltage range of multipactor appearance was passed in 2 hours,

accelerating voltage of 225 kV was obtained on the cavity at 10^{-8} torr vacuum. The coupling constant of the power input was insufficient, so a transformer was installed before the power input.

At the third stage, a new power input with enlarged loop was installed. The cavity was installed into the damping ring and isolated from its chamber by two vacuum valves. $2 \cdot 10^{-9}$ torr vacuum was obtained in the cavity, so it was decided to carry out RF tests without pre-heating.

Multipactor area was observed in the accelerating voltage range of 22...60 kV. After 5-hour conditioning in the pulsed mode, continuous regime was activated and multipactor range was easily passed at rapid voltage rise. Multipactor range conditioning for 15 hours in continuous regime led to vacuum improvement from $1.6 \cdot 10^{-6}$ torr to $2.7 \cdot 10^{-7}$ torr in this area. The conditioning will be continued.

In continuous regime, accelerating voltage of 225 kV was obtained for a long time at 11.5 kW power dissipated in the cavity and 10^{-8} torr vacuum. At resonant tuning, the reflected wave is rather small (VSWR=1.19) and cavity voltage is determined by measured incident wave power and cavity parameters. The maximal heating (up to 60° C) was observed at the cavity sidewall near the frequency turning flange. The temperature frequency deviation was 150 kHz. The klystron generator operated at the anode voltage of 20.2 kV and gain of about 46 dB.

6. CONCLUSION

As a result of low and high power level tests of the RF system, the parameters which provided the damping ring operating were obtained. The voltage range at which the multipactor in the cavity is observed lies below the accelerating voltages of 100...150 kV which are required for beam capturing into the ring. The multipactor is easily passed at rapid voltage increase.

RF system operating with the beam is planned for the end of 2005.

REFERENCES

1. N.S. Dikansky et al. Proc. of EPAC'94. London. 1994, p.482-484.
2. N. Alinovsky et al. Proc. of EPAC'98, IEEE. 1999, v.3, p.1799-1803.
3. D. Bolkhovityanov et al. Proc. of the XVII Workshop on Charged Part. Acc., Protvino. 2000, v.1, p.51-54 (in Russian).

СТАТУС ВЧ-СИСТЕМЫ НАКОПИТЕЛЯ-ОХЛАДИТЕЛЯ ВЭПП-5

Е. Гусев, Н. Кот, С. Крутихин, И. Куццов, Г. Куркин, И. Макаров, Н. Матяш, Л. Мироненко, С. Мотыгин, В. Осипов, Г. Острейко, В. Петров, А. Попов, Е. Ротов, И. Седляров, Г. Сердобинцев, А. Штейнке, В. Тарнецкий, А. Фролов, К. Чернов, В. Волков

Представлена ВЧ-система накопителя-охладителя для ВЭПП-5, созданная в БИЯФ, Новосибирск. ВЧ-система работает на частоте 700 МГц и состоит из генератора на клистроне КУ-393, передающего волновода с коаксиально-волноводными переходами, ускоряющего резонатора и системы управления и контроля. Для устранения пучковой неустойчивости высшие моды резонатора подавлены с помощью резистивных нагрузок. Приведены параметры и результаты холодных измерений и горячих испытаний ВЧ-системы.

СТАТУС ВЧ-СИСТЕМИ НАГРОМАДЖУВАЧА-ОХОЛОДЖУВАЧА ВЕПП-5

Е. Гусев, Н. Кот, С. Крутихин, И. Куццов, Г. Куркин, И. Макаров, Н. Матяш, Л. Мироненко, С. Мотыгин, В. Осипов, Г. Острейко, В. Петров, А. Попов, Е. Ротов, И. Седляров, Г. Сердобинцев, А. Штейнке, В. Тарнецкий, А. Фролов, К. Чернов, В. Волков

Представлено ВЧ-система нагромаджувача-охолоджувача для ВЕПП-5, що створена в БИЯФ, Новосибірськ. ВЧ-система працює на частоті 700 МГц і складається з генератора на клістріні КУ-393, передаючого хвилеводу з коаксіально-хвилеводними переходами, прискорюючого резонатора і системи керування і контролю. Для усунення пучкової нестійкості вищі моди резонатора подавлені за допомогою резистивних навантажень. Наведено параметри і результати холодних вимірів і гарячих випробувань ВЧ-системи.