

# ELECTRON ACCELERATOR FOR ENERGY UP TO 5.0 MeV AND BEAM POWER UP TO 50 kW WITH X-RAY CONVERTER

*V.L. Auslender, A.A. Bryazgin, V.G. Cheskidov, I.V. Gornakov, E.N. Kokin, G.I. Kuznetsov,  
A.N. Lukin, I.G. Makarov, S. A. Maximov, V.E. Nekhaev, G.N. Ostreiko, A.D. Panfilov,  
V.M. Radchenko, N.D. Romashko, A.V. Sidorov, M.A. Tiunov, V.O. Tkachenko, A.F. Tuvik,  
L.A. Voronin, B.L. Faktorovich  
Budker Institute of Nuclear Physics,  
11, Academician Lavrentiev avenue, Novosibirsk, 630090, Russia;  
E-mail: vtkachen@inp.nsk.su*

The paper describes the industrial electron accelerator ILU-10 for electron energy up to 5 MeV and beam power up to 50 kW specially designed for use in industrial applications. The ILU-10 accelerator generates the vertical electron beam. The beam line turns the beam through an angle of 90° and transports the beam to the vertically posed X-ray converter to generate the horizontal beam of X-rays.

PACS: 29.17.+w

Since 1970, BINP SB RAS has been developing and manufacturing the ILU-type electron accelerators for the applications in the research and industrial radiation-technological installations. The design and schematic solutions of the installations envisage a continuous round-the-clock operation under conditions of industrial production.

The ILU-type accelerators overlap the energy range from 0.7 to 5 MeV at an accelerated beam power of up to 50 kW. The intrinsic features of these accelerators are the simple design, ease in maintenance and the long term reliable operation under conditions of industrial production. Table shows the basic parameters of the ILU-type accelerators produced by BINP [1, 2, 3].

Parameters	ILU-6	ILU-8	ILU-10	ILU-11
Energy of electrons, MeV	1.2...2.5	0.6...1.0	2.5...5.0	2.0...4.0
Average beam power (max), kW	20	25	50	20
Average beam current (max), mA	20	30	15	4
Power consumption, kW	100	80	150	120
Accelerator weight, tons	2.2	0.6	2.9	2.5
Weight of local protection, t	-	76	-	-

The basic model of the ILU accelerators is the ILU-6 accelerator [1]. On the base of the ILU-6 accelerator, the ILU-10 accelerator was developed taking into account requirements of the technological processes during irradiation of various materials. This work is devoted to its description.

## GENERAL DESCRIPTION OF ILU-10 ACCELERATOR

The basic component of the accelerator is a toroidal copper cavity with an operating frequency of 116 MHz with cone-shaped axial protrusions forming the accelerating gap of 270 mm in length. The protrusion shape was chosen from the conditions of the formation and focusing of an electron beam in the processes of its injection, acceleration and further passage through the extraction system with minimum losses.

The cavity 2 is placed into the vacuum tank 1 (Fig.1). On the upper electrode insulator, the cathode unit is mounted, which together with a grid form the injector of electrons 5. The lower electrode and injector form a triode accelerating system. The beam current of accelerated electrons is controlled by varying the value of the positive bias at the cathode with respect to the grid.

Under the lower electrode of the cavity there is a magnetic lens shaping an electron beam in the accelerator channel and the extraction device 6.

Two single-cascade high frequency autogenerators based on powerful triodes of the GI-50A type are installed directly on the vacuum tank. Generators 9 assembled according to the common grid circuit are operated in the selfexcitation regime at a frequency close to the specific frequency of the cavity. Anode circuits are connected to cavities through the inductance loops. The link value with a cavity is determined by the area of a loop and an adjustment of the anode circuits with respect to the cavity frequency. The generator feedback is provided by the additional capacitance made in the form of a disk inserted between the tube anode and cathode.

This capacitance is of 20 pF. The fine tuning of the feedback value and its phase is made by the cathode short-circuited tail with a movable shortcut contact moved by a servodrive. The value of the generator - cavity link is selected during the accelerator preliminary adjustment by varying the capacity of the vacuum capacitor 8 and the area of the link loop by varying the position of the support 7.

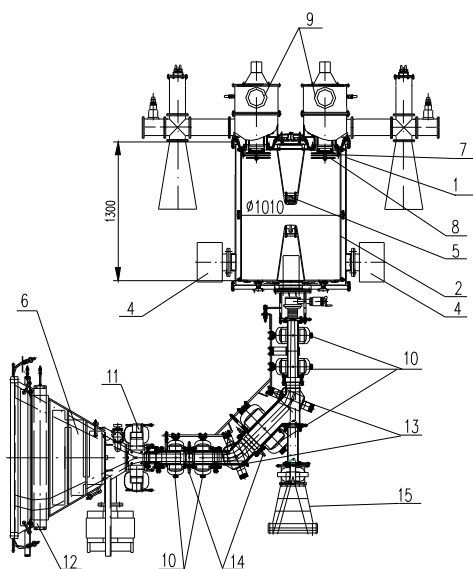

*Fig.1. ILU-10 Accelerator:*

*1-vacuum tank; 2-copper toroidal cavity; 3-magnetic lens; 4-spallation pumps; 5-cathode unit; 6-extraction device; 7-support of coupling loop; 8-vacuum capacitor; 9-RF-generators; 10-quadrupole lenses; 11-scanning magnet; 12-correcting magnet; 13-bending magnets; 14-pick-up stations; 15-direct extraction device*

The measuring loop is installed on the upper flange of the tank. Its signal proportional to the cavity gap voltage is used for measuring the energy of accelerated electrons.

For stabilization of the leading front of the high frequency voltage pulse when applying the pulse voltage to the tubes anode, an additional excitation of the generator by the direct voltage of 0.9...1.5 kV is used.

The cavity is placed into the vacuum vessel made of stainless steel. Pumping by four spallation pumps of the NMD-0.4 type located at the cylindrical side surface is provided by the forevacuum aggregate through the nitrogen trap. All the sealings in the vacuum vessel are made of metal (copper and indium). The operating vacuum is of  $10^{-7}$  torr. For the normal operation of the vacuum system, intervals of about two days do not require the forevacuum pumping for switching on the spallation pumps. The vacuum tank pressure is measured by the current value in the spallation pumps. The ILU-10 accelerator is a novel development and it is mainly designed for the processes requiring high energies of electrons and beam power.

The accelerator overall dimensions are somewhat larger than those of the ILU-6 accelerator. In order to increase the beam power, two RF generators are installed at the ILU-10 accelerator (ILU-6 is used with single RF generators).

## ELECTRON BEAM EXTRACTION

In recent years, in the majority of countries the beam technologies are being developed aiming at their use for irradiation products in the food industry. However, in the use of the electron-beam technology one should take

into account that the electron beam permeability is rather small thus putting limitation to the amount of the irradiated material. A reasonable alternative seems to be the use of powerful fluxes of X-rays. A simple way of generation such a radiation, is to direct the beam to the converter.

The technological process of the product treatment assumes a choice of some or other type of the extraction device. For example, the beam bent at an angle of 90 grades enables a substantial simplification in the design of the conveyor system for applying the treated product to two-sided irradiation.

General view of the bending system design is given in Fig.1 [4]. The beam from the accelerator reaches the bending channel and is turned there through an angle of 90 grades and hits vertical long optimized X-ray converter, which is an aluminum plate coated by the layer of tantalum.

The channel is an electron optical system having two 45 grades bending magnets with the parallel ends, quadruple lens with a large radial aperture, two adjustable lens doublets, scanning magnet and correcting magnet. The scanning magnet in a period of 500  $\mu$ s scans the beam from above to down along the converter of 1 m in length. The scanning angle is ranging from -25 to +25 grades.

For the formation of the technologically optimum dose field, an electron beam should be incident at the converter edges at an angle close to 90 grades. This is provided by the use of the correcting magnet located at 15 cm to the converter.

All the components of the beam channel have the water cooling systems enabling to remove totally of up 5 kW heat in a continuous regime. The system of vertical extraction of a beam through the titanium foil is kept for expanding the technological capabilities of the accelerator.

The ILU-10 accelerator is the RF machine and so the initial energy spectrum of electrons in the beam is not monochromatic but has the certain energy spread. To increase the X-ray power the energy spectrum of electrons ought to be made more narrow and the part of electrons with maximum energy ought to be increased because the electrons of the low energy part of spectrum do not make the input into the X-ray power, and their energy is transformed into the heating of target. It is possible to improve the energy spectrum of electron beam (to decrease the part of low energy electrons) by applying the high frequency bias voltage on the grid-cathode gap of the accelerator's electron gun as it is shown in Fig.2.

The high frequency bias voltage is supplied from the accelerator's resonator through the loop and is passing to the matched load and grid-cathode gap of electron gun through the phase shifter. The amplitude of RF voltage is regulated by the plunging depth of the loop, and the phase shift is regulated by changing the tuning of phase shifter. Choosing the amplitude and phase of RF bias voltage on electron gun it is possible to shift the phase of the current pulse regarding the accelerating voltage and so to improve the energy spectrum of the electron beam.

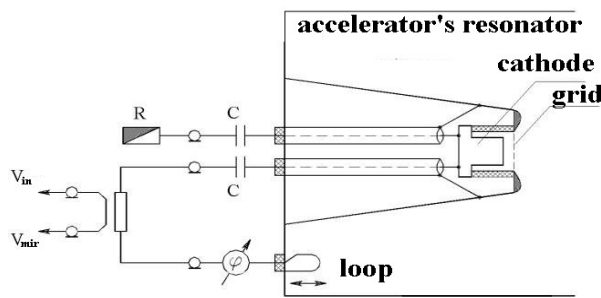

Fig. 2. Circuit for RF bias voltage supply onto the electron gun

The efficiency of energy spectrum correction by applying the HF bias voltage onto the electron gun was checked by measuring the energy spectrum of the beam generated by existing the accelerator ILU-10 with a beam power up to 50 kW. The results of the measurements are shown in Fig.3.

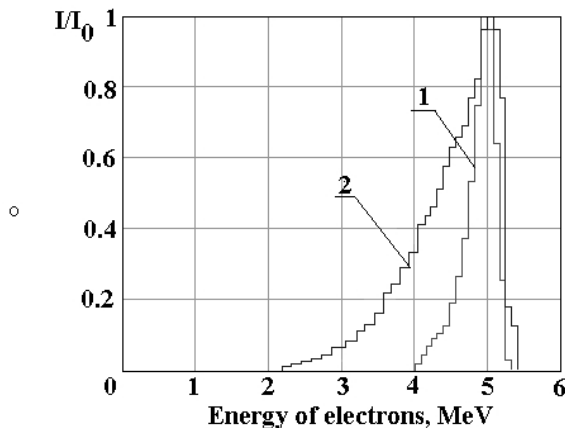

Fig. 3. Energy spectrum of the ILU-10 electron beam 1 -with and 2 - without applying the RF bias voltage onto the electron gun

## RESULTS

During the tests the following parameters are obtained: the maximum electron energy of 5.5 MeV at a low beam power, electron energy of 5 MeV at a beam

power of 50 kW and 4.5 MeV at a beam power of 60 kW. The operating mode is a pulsed mode, the maximum pulse repetition rate of 50 Hz, a pulse duration of 400...500 mks.

In the work with the tantalum converter, a rather homogeneous dose distribution at the irradiated material surface was obtained. At the scanning width of 60 cm, the average dose value was 18 kGray with the conveyor equivalent speed of 1 mm/s.

## REFERENCES

1. V.L.Auslender. ILU-type electron accelerator for industrial technologies // *Nucl. Instruments and Methods in Physical Research*. 1984, v. B 89, p.46-48.
2. V.L.Auslender, A.A.Bryzgin, L.A.Voronin, G.A.Vasiliev, V.A.Gorbunov, M.Korobeinikov, V.N.Kokin, S.A.Maximov, V.E.Nekhaev, A.D.Panfilov, V.M.Radchenko, V.O.Tkachenko, A.A.Tuvik, B.L.Factorovich. ILU-type electron accelerators with energies higher than 5.0 MeV and power over 50 kW//*Abstracts of Proceedings of XVII Workshop on Accelerators of Charged Particles, Protvino, 2000*.
3. V.L.Auslender, A.A.Bryazgin, G.B.Glagolev, V.A.Gorbunov, S.A.Maximov, V.E.Nekhaev, A.D.Panfilov, V.O.Tkachenko, A.A.Tuvik, B.L.Factorovich. ILU-series electron accelerators and their applications in the industry and medicine//*IX All-Russian Workshop on applications of electron accelerators in industry and medicine, Sankt-Petersburg, Russia, 22-24 Sept., 1998*.
4. V.L.Auslender, E.A.Bekhtenev, A.A.Bryazgin, L.A.Voronin, N.I.Zenevich, E.N.Kokin, G.S.Krainov, S.V.Miginsky, V.M.Radchenko, N.I.Saputin, V.O.Tkachenko, B.L.Factorovich. Akhromatic system of the electron beam bending at 90 grades in the ILU-10 accelerator//*Proceedings of X International Workshop on applications of the charged particle accelerators in industry and medicine. Sankt-Petersburg. M: ZNIIatominform, 2001*.

## УСКОРИТЕЛЬ ЭЛЕКТРОНОВ 5 МэВ 50 кВт С ТОРМОЗНОЙ МИШЕНЬЮ

*В.Л. Ауслендер, А.А. Брызгин, В.Г. Ческидов, И.В. Горнаков, Е.Н. Кокин, Г.И. Кузнецов, А.Н. Лукин, И.Г. Макаров, С.А. Максимов, В.Е. Нехаев, Г.Н. Острейко, А.Д. Панфилов, В.М. Радченко, Н.Д. Ромашко, А.В. Сидоров, М.А. Тиунов, В.О. Ткаченко, А.А. Тувик, Л.А. Воронин, Б.Л. Факторович*

Приводится описание ускорителя электронов ИЛУ-10 на энергию 5 МэВ мощностью 50 кВт, специально разработанного для таких комплексов. Для упрощения конструкции конвейерной системы подачи обрабатываемой продукции в зону облучения используется выпускное устройство с поворотом пучка на 90 градусов и последующей конвертацией электронного пучка в гамма-излучение на вертикально расположенной мишени.

## ПРИСКОРЮВАЧ ЕЛЕКТРОНІВ 5 МэВ 50 кВт З ГАЛЬМОВОЮ МІШЕНЬЮ

*В.Л. Ауслендер, А.А. Брызгин, В.Г. Ческидов, И.В. Горнаков, Е.Н. Кокин, Г.И. Кузнецов, А.Н. Лукин, И.Г. Макаров, С.А. Максимов, В.Е. Нехаев, Г.Н. Острейко, А.Д. Панфилов, В.М. Радченко, Н.Д. Ромашко, А.В. Сидоров, М.А. Тиунов, В.О. Ткаченко, А.А. Тувик, Л.А. Воронин, Б.Л. Факторович*

Приводиться опис прискорювача електронів ІЛУ-10 на енергію 5 МэВ потужністю 50 кВт, спеціально розробленого для таких комплексів. Для спрощення конструкції конвеєрної системи подачі оброблюваної продукції в зону опромінення використовується випускний пристрій з поворотом пучка на 90 градусів і

наступною конвертацією електронного пучка в гамма-випромінювання на вертикально розташованій мішені.