

LINEAR CHARGED-PARTICLE ACCELERATORS

<https://doi.org/10.46813/2021-133-064>

ADJUSTMENT OF RESONANCE FREQUENCY IN H-STRUCTURES ACCELERATING

S.O. Vdovin, Ye.V. Gusev, L.D. Lobzov, O.P. Podolayk, M.G. Shulika

National Science Center “Kharkov Institute of Physics and Technology”, Kharkiv, Ukraine

E-mail: vdovin@kipt.kharkov.ua

It is necessary to adjust the resonant frequency of the accelerating structures during operation of high-frequency linear accelerators on the H-wave. The deviation of the resonant frequency of the resonator from the calculated value is due to the connection of input devices and control of RF power when changing the level of matching of the resonator with the feeder line that transports the RF power to the resonator, as well as when changing the temperature mode of the resonator. The problem is especially urgent when the accelerator structure consists of several resonators. The paper presents the designs of several resonant frequency tuners and the results of their research. The influence of the change of the frequency of oscillations excited in the accelerating structure on the parameters of the accelerated beam is considered.

PACS: 29. 20. Ej

INTRODUCTION

The development of linear accelerators of ions operating on the H-type wave is due to the expansion of a number of physical problems solved with the help of charged particle beams. Structures on the H-wave, unlike the resonators operating on the E-wave, have smaller dimensions and volume of energy. High values of shunt resistance, higher acceleration rates and low injection energy. The modes of high-frequency excited oscillation in such structures differ from the basic mode used to accelerate particles by several tens of megahertz. Such structures are more stable with changes in temperature. However, when operating the accelerators, there is a necessity of exact adjustment the resonator to the operating – resonant frequency and to stabilize it during operation.

In the process of creating an accelerating resonator in the final stage, the control and tuning of the electrodynamic characteristics (EDC) of the resonator is carried out. Measured resonant frequencies of the working mode of oscillations and several higher modes, the quality factor, the correspondence of the acceleration field distribution on the resonator axis to the requirements determined during the development of the acceleration channel is checked. This process is carried out in the absence of devices that connect to the resonator during operation. Connecting such devices and matching them with the accelerator resonator causes the resonator parameters to deviate from the calculated values. The deviation of the resonator parameters can also occur when changing the resonator temperature during the accelerator operation. To compensate for the deviation of the resonant frequency from the calculated value in the resonators, special devices adjust. The required tuning range of the resonant frequency is determined by the requirements of the joint operation of the accelerating structure with the sources of RF power and systems for automatic control of the RF parameters in the resonator in the process.

ADJUSTMENT FREQUENCY IN H-RESONATOR

The loaded H-resonator is a system of coupled circuits formed by the inductances and capacities of the drift tubes and their attachment elements in the resonator. It is convenient to use a method similar to that used to adjust the resonator to the given EDC to adjust the resonant frequency to the calculated value [1]. It is based on the dependence of the high-frequency parameters of the resonator on the change in the frequency characteristics of the acceleration periods (connected circuits), which have a strong connection between themselves and the general field of the resonator. Adjusting the resonant frequency by changing the parameters of the acceleration periods after tuning the resonator to the given parameters is impossible, as it will lead to a deviation of the acceleration field distribution from the calculated one. Therefore, various passive resonant devices are placed in the resonator to adjust the resonant frequency. Such devices – frequency tuners must couple with the high-frequency field of the entire resonator, that is, create an additional system of connected circuits between the resonator and additional resonant device. The processes occurring in the system resonator – frequency tuner are similar to the processes occurring in the coupled RF circuits. Changing the resonant frequency of the tuner causes a change in the resonant frequency of the coupled circuit, and hence the frequency of resonator. The frequency tuner is coupled to the resonator through the magnetic component of the resonator electromagnetic field. The type of the change in the resonant frequency and the magnitude of the adjustment are determined by the ratio of the resonant frequencies of the circuits and the coupling coefficient between them.

Variant of the frequency tuner of the type of the loop with the concentrated capacity is shown in Fig. 1. Constructively resonant contour of the tuner is made as a closed flat coil of copper plate loaded on the capacity. The capacitors were flat parallel plates formed by the bends of the copper plate of the coil.



Fig. 1. Resonant frequency tuner of the type of the loop with the concentrated capacity

The adjustment of the frequency of the tuner, and therefore the coupled resonator, was realized by changing the distance between the plates of the capacitor by means of a rod with a micrometer screw. The tuner was mounted on the inner side surface of the resonator. The contour axis is arranged parallel to the axis of the accelerator channel so that it coincides with the longitudinal component of the magnetic field excited in the resonator. The interaction with the high-frequency field of the resonator was carried out with the longitudinal component of the magnetic field excited in the resonator.

Fig. 2 shows a typical frequency diagram for the first three modes of oscillation obtained in the study of the H-resonator.

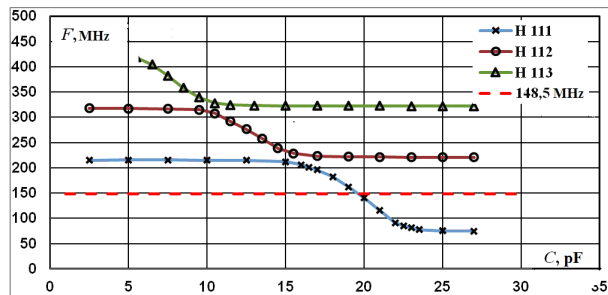

Fig. 2. The dependence of the frequency spectrum of the H-resonator on the value capacitance of the frequency tuner

The dotted line plots the resonant frequency of the first mode used to accelerate. The resonance frequency tuning range is related to the magnitude of the coupling factor between the tuner and resonator circuits. To extend the range, it is necessary to increase the mutual inductance of the circuits, that is, the size of the tuner's loop. But this will increase the reactivity of the coupling between circuits, which will impair the EDC of the resonator. In addition, the size of the tuner is limited by the condition of small perturbation of the characteristics of the resonator with additional devices that accommodate the middle cavities of the resonator. Thus, the frequency adjusting range of the loop with the concentrated capacity is limited, among other things, by the size of the device. The resonant frequency tuner which shown in Fig. 1 provided a frequency adjustment range within 1 MHz.

The simplest design of the frequency tuner is a turn closed on itself. It had the appearance of a closed ring in the form of a semicircle. The turn was made of copper

wire 6 mm thick. The half-circle portion of the contour was connected to the lateral inner surface of the resonator by means of a sliding contact. The flat part was turned to the holders on which the drift tubes of the accelerator channel were attached. The H-resonator of the MLUD – 3 accelerator was used as the resonant circuit [2]. The location of the tuner in the resonator is shown in Fig. 3.

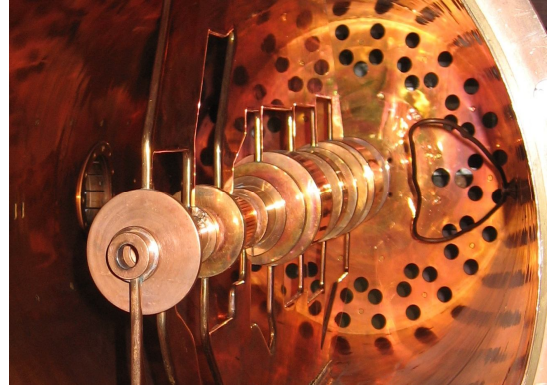

Fig. 3. Resonant tuner type of turn closed on itself

As in the first case, the circuit interacts with the longitudinal component of the high-frequency magnetic field of the resonator. Frequency adjusting was performed by rotating the circuit around its axis, which provided a smooth change in the coupling coefficient with the electromagnetic field of the resonator by changing the effective area of the loop. The maximum turning angle was 90° . The frequency tuning range was 0.5 MHz. The dependence of the frequency spectrum in the resonator is similar to the dependence presented in Fig. 2. In the horizontal position of the circuit, the resonant frequency of the resonator – circuit system was equal to 98.2 MHz. With the vertical position corresponding to the maximum interaction area, the frequency was 97.7 MHz. Q-factor of the resonator varied from 7700 at 98.2 MHz to 6800 at 97.7 MHz. The second and third modes of oscillation in the resonator had frequencies of about 133 and 335 MHz, respectively.

In order to reduce the influence of additional devices on the EDC of the resonator a system for resonance frequency tuning was developed that consisted of two feeder adjusters located outside the resonant cavity on the outside of the accelerator vacuum chamber. Fig. 4 shows schematically the design of an accelerating resonator system with two frequency adjusters.

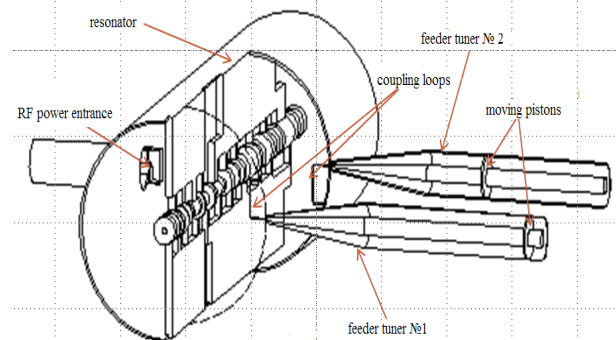

Fig. 4. Resonator with the feeder frequency tuner

The tuners were coaxial resonators, with outer and inner diameters of 90 and 41 mm, respectively. The resonant frequency of these resonators was adjusted by moving pistons. The position of the plungers determined the electrical length of the resonators and therefore their resonant properties. The inductive coupling with the electromagnetic field of the resonators was carried out with the help of loops mounted on the inner side surface of the resonator. The depth of immersion of the coupling loops in the resonator and their size determined the coupling coefficient of the adjusters with the resonator. The coupling loop of one tuner was pointing upwards relative to the horizontal plane of the resonator, the second one downwards to eliminate the direct coupling of the tuners to each other. As a result of optimization parameters of the system accelerating resonator – tuner resonator, the optimum depth of immersion of the coupling loops in the accelerator resonator was found and the size of the loops was determined. They were equal to 50 and 100 mm respectively.

Fig. 5 shows the dependence of the resonant frequency and the Q-factor of the accelerating resonator when changing the length of the resonator one of the tuners, which were obtained using automated complex ABK [3].

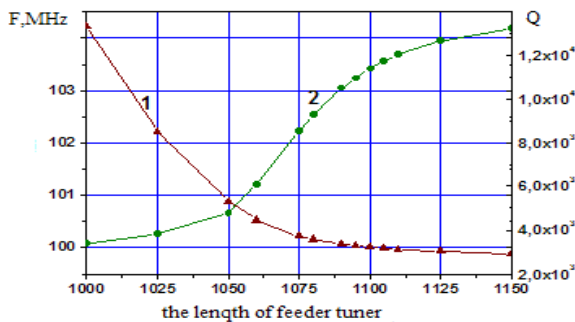

Fig. 5. Dependence of resonant frequency (1) and Q-factor (2) on the length of the tuner

The length of the second tuner was half the wavelength in the accelerating resonator 1500 mm. The length of the tuners was counted from the side surface of the accelerating resonator. Q-factor of the resonator varied from ~4000 to ~13000 with the resonance frequency adjusted in the range from 99.8 to 104.0 MHz. The change of the Q-factor was due to the dependence of the coupling factor of the tuner with the resonator on the frequency change of the tuner. The influence of the coaxial resonator of the tuner on the parameters of the accelerating resonator increased with increasing coupling coefficient. That was the cause of the worsening of the EDC of the accelerating resonator.

The closest, higher resonance frequencies that could be excited in a system of the accelerating resonator with a tunable coaxial resonator differed from the main (operating) frequency by a few megahertz. This is much larger than the width of the amplitude-frequency response of the resonant system and eliminates the influence of parasitic (higher) modes of oscillation on the resonator's operation.

CHARACTERISTICS OF THE ACCELERATED BEAM

Changing the resonant frequency of the accelerating resonator causes a change in the distribution of the electric field amplitude in the gaps of the accelerating periods. Fig. 6 shows the change in the distribution of the acceleration field module on the axis of the resonator in the frequency tuning range ± 800 kHz from the calculated value. The red dashed line shows the computed field distribution. Amplitude values are normalized to the magnitude of the field in the fourth acceleration period, which has the maximum value.

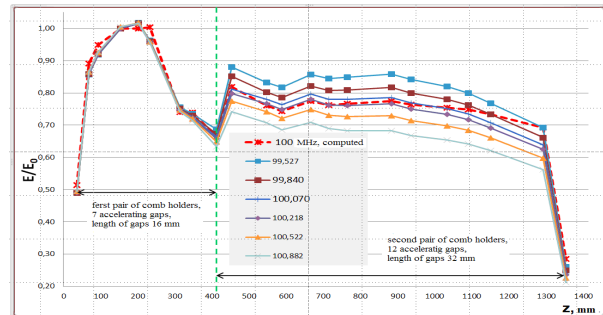

Fig. 6. The distribution of the field on the axis of the resonator when changing the resonant frequency

The deviation of the acceleration field distribution from the calculated one changes the dynamics of the beam in the accelerator channel and the parameters of the accelerated beam. To determine the nature of the impact, numerical studies of beam dynamics were performed when changing the acceleration field distribution in the specified frequency range.

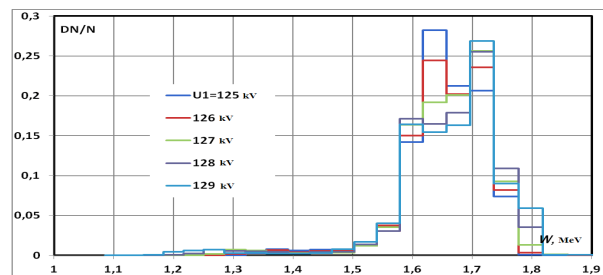

Fig. 7. The energy spectrum of the beam at 99.8 MHz depending on the potential difference between the "combs"

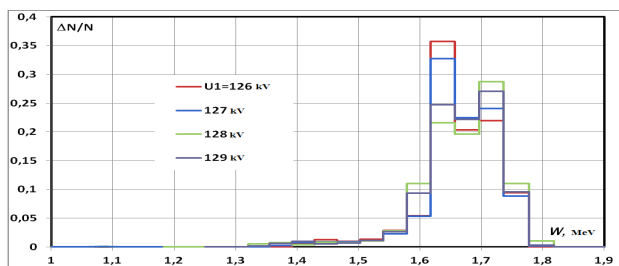

Fig. 8. The energy spectrum of the beam at 100.2 MHz depending on the potential difference between the "combs"

The results of the study for two values of the resonant frequency (below and above the calculated value by 200 kHz) for several values of the potential difference between flat plates – "combs" are shown in Figs. 7 and 8.

Changing the resonant frequency of the accelerating section and the potential difference between the combs leads to a change in the average energy of the beam and a change in the width of its energy spectrum.

At a higher value of the resonant frequency, the energy width of the particle beam is approximately 0.1 MeV. The change in the potential at the combs leads to a shift the maximum of energy distribution of particles by 0.2 MeV.

CONCLUSIONS

The deviation of the oscillation frequency from the operating frequency leads to a change in the amplitude distribution of the electric field in the gaps of the accelerating structure. As the operating frequency increases by one percent, the field amplitude in the acceleration gaps decreases by about ten percent. The deviation of the acceleration field distribution leads to both a change in the average beam energy at the output of the accelerator resonator and to a change in the width of its energy spectrum. Devices designed to adjust the frequency of the resonator allow you to vary the operating frequency

within up to 4 MHz. In this case, the EDC of the resonator remain within acceptable values.

REFERENCES

1. S.A. Vdovin, Ye.V. Gusev. Specificity of Simulation of Low Energies Acceleration Structures // *Problems of Atomic Science and Technology. Series "Nuclear Physics Investigations"*. 2019, № 6, p. 3-8.
2. S.O. Vdovin, Ye.V. Gusev, P.O. Demchenko, M.G. Shulika. Linear Deuteron Accelerator for Element Analysis // *Problems of Atomic Science and Technology. Series "Nuclear Physics Investigations"*. 2010, № 2, p. 33-37.
3. G.A. Bryzgalov, Ye.V. Gusev, N.P. Klimko, et al. Automated measuring complexes for investigation of microwave parameters of irregular acceleration structures // *Problems of Atomic Science and Technology. Series "Physical Experiment Technique"*. 1986, № 2, p. 50-52.

Article received 08.12.2020

ПОДСТРОЙКА РЕЗОНАНСНОЙ ЧАСТОТЫ В УСКОРЯЮЩИХ Н-СТРУКТУРАХ

С.А. Вдовин, Е.В. Гусев, Л.Д. Лобзов, А.П. Подоляк, Н.Г. Шулика

В процессе эксплуатации высокочастотных линейных ускорителей ионов на Н-волне необходимо корректировать резонансную частоту ускоряющих структур. Отклонение резонансной частоты резонатора от расчетного значения происходит вследствие подключения к нему элементов ввода её мощности и контроля, при нарушении степени согласования входного сопротивления резонатора с волновым сопротивлением фидерной линии, по которой ВЧ-мощность поступает в ускоритель, а также при изменении его температурного режима. Проблема особенно актуальна в случае, когда ускоряющая структура состоит из нескольких резонаторов. Представлены конструкции нескольких настройщиков резонансной частоты и результаты их исследований. Изучено влияние изменения частоты колебаний, возбуждаемых в ускоряющей структуре, на параметры ускоренного пучка.

ПІДСТРОЮВАННЯ РЕЗОНАНСНОЇ ЧАСТОТИ В ПРИСКОРЮВАЛЬНИХ Н-СТРУКТУРАХ

С.О. Вдовін, Є.В. Гусєв, Л.Д. Лобзов, О.П. Подоляк, М.Г. Шуліка

У процесі експлуатації високочастотних лінійних прискорювачів іонів на Н-хвилі необхідно коригувати резонансну частоту прискорювального резонатора. Відхилення резонансної частоти резонатора від розрахункового значення відбувається внаслідок підключення до нього пристроїв введення і контролю ВЧ-потужності при зміні рівня узгодження резонатора з хвильовим опором фідерної лінії, яка транспортує ВЧ-потужність у прискорювач, а також при зміні його температурного режиму. Проблема особливо актуальна в разі, коли прискорювальна структура складається з декількох резонаторів. Представлено конструкції кількох настроювачів резонансної частоти та результати їх досліджень. Розглянуто вплив зміни частоти коливань збуджуваних у прискорювальній структурі, на параметри прискореного пучка.