

# PULSED INJECTOR OF THE WORKING SUBSTANCE FOR MAGNETOPLASMA COMPRESSOR

V.V. Staltsov

National Science Center "Kharkov Institute of Physics and Technology", Kharkov, Ukraine

Technical description of the high-speed pulsed injector of working substance with a radial gas supply for magnetoplasma compressor is given. The results of studies on the main gas-dynamic and electrotechnical characteristics of the gas injector are presented.

PACS: 47.80.+v; 51.35.+a; 52.50.D

## INTRODUCTION

Today plasmodynamic systems of acceleration and compression type are widely used in various fields of science and technology [1 - 4]. Plasma technologies are the basis of many processes for the treatment and hardening of the surface of various materials, coating deposition, welding of different materials, deposition of ultrathin films on the surface of the parts, simulation of thermonuclear processes [5 - 12]. Plasmodynamic compression-type systems are considered as promising sources of ultraviolet and x-ray radiation, which are used for laser pumping, in lithography, for sterilization of medical equipment etc. [13 - 15]. The plasmaforming substance injectors which are used for injection of working gas to the discharge gap of the plasmadynamic system play the main role in the formation of plasma flows with the specified energy parameters [16, 17]. For generation and study of high-voltage compression plasma flows, the magnetoplasma compressor (MPC) of compact geometry was developed, manufactured and tested. MPC allows working using plasma-forming gases of different masses and their mixtures. For the dense magnetized plasma source, the pulsed injector of MPC working substance was developed in versions with radial and axial overlap of the working gas. The MPC pulsed gas injector is used for the supply of working gas to the MPC discharge gap for its subsequent ionization and generation of high-density plasma [14 - 17].

## DESIGN OF THE PULSED INJECTOR FOR THE MPC WORKING FLUID

The MPC pulsed injector for the working substance with radial overlap, including cut-away view, is presented in Fig. 1. The assembly drawing of the MPC pulsed injector for the working substance is presented in Fig. 2.

During the development of the valve assembly for the MPC working substance, the mechanism of electrodynamic type was considered as basic. The principle of operation of this mechanism is based on the interaction of time-varying electromagnetic field coil with vortex currents induced by this field in a conductive plate. The MPC working substance injector is built-in, i.e. the individual parts of the injector are conductive elements of the plasma source axial electrode.

The gas injector enclosure is the tip of the axial electrode 1 (see Fig. 2). The injector locking sleeve 2 is located in the inner groove of the axial electrode 1. The locking sleeve 2 is welded to the tube of the rod 3. The opposite end of the rod tube 3 is welded to the threaded shank 4.

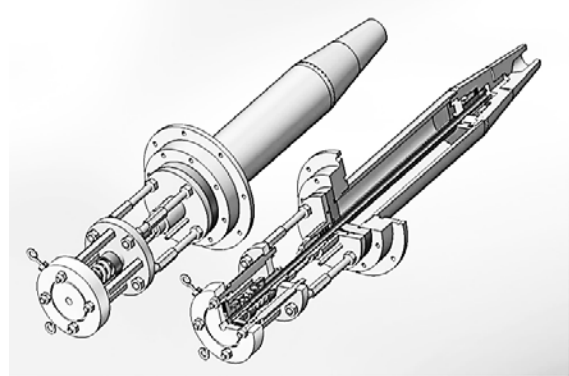

Fig. 1. The MPC pulsed injector for the working substance with radial overlap injector pulse of the working substance of the IPC in the version with radial overlap

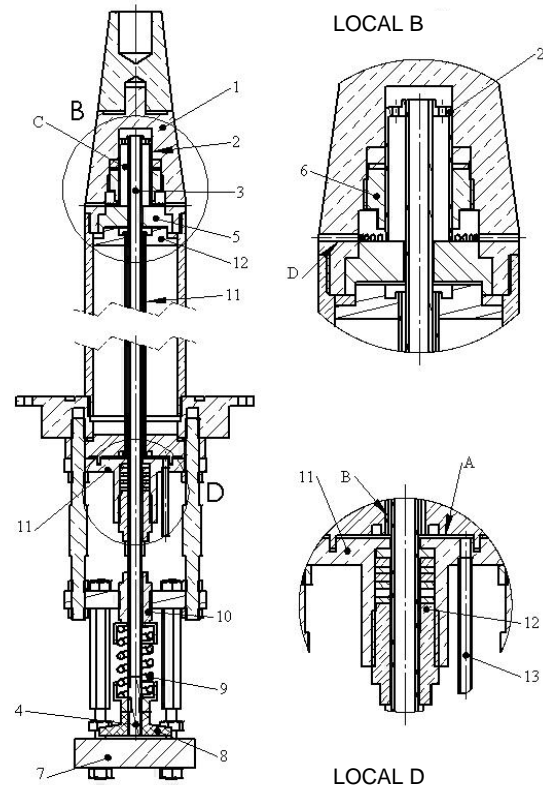

Fig. 2. The assembly drawing of the MPC pulsed injector for the working substance

The sealing lip of the sleeve 2 is based on the seat 5. The outer cylindrical surface of the locking sleeve 2 is sealed by the seal assembly 6. The valve assembly of the injector is driven by the electromagnetic coil 7. The coil 7 has influence on the locking sleeve 2 via the anvil 8 and rod 3, 4. Retraction of the locking sleeve 2 is carried out by the damping unit 9. The unit 9 includes a

compression spring and locking sleeves. The threaded bush 10 is used for adjustment of the spring 9 compressive force. To hermetically seal the outer surface of the pipe for the shaft 3 in the holder 11, a vacuum input section 12 was made. The input section 12 allows axial displacement of the rod and retention of the tightness at the moment of injector operation.

The pulsed injector of the MPC working substance operates as follows. The working gas is supplied to the cavity A through the gas supply tube 13. After this, gas is supplied to the booster cavity C of the locking element 2. The working gas is accumulated in the cavity before injection to the discharge gap of MPC. Initially, the return spring of the damping unit 9 presses the gas rod and, correspondingly, the sealing belt of the locking sleeve 2 to the seat 5 and cuts the booster cavity from the gas supply channels D.

In the known gas injectors, the locking element, except for the force of pressing by the return unit, is usually pressed to the seat by the gas pressure in the booster gas cavity. Depending on the area of the locking element, this additional pressing force can be quite significant. That is, as the gas pressure in the booster gas cavity is increased for opening the locking element, the current rate should be increased for the winding of the electromagnetic coil. This results in loading of the coil elements with additional electrodynamic forces and reduces its lifespan. Witnessing this embodiment, the locking sleeve 2 is not influenced by the gas pressure. At the bottom of the locking sleeve 2 there are the holes through which the gas from the sleeve cavity C is supplied to the inner cavity E. The same gas pressure in the cavities C and E balances the force of gas pressure for the movable elements of the system. Such technical approach to the design of the locking unit allows working with the gas pressure in the gas cavity up to 30 atm. This factor allows obtaining high-speed gas flow in the process of working gas injection to the acceleration channel of the plasmodynamic device and obtaining of the "sharp" front edge of the gas pulse.

The working gas is injected as follows. After supplying the driving pulse to the winding of the coil 7, the time varying electromagnetic field of the coil induces vortex currents in the anvil 8. The anvil 8 is screwed onto the threaded shank of the rod 4. The interaction of the electromagnetic field of the coil 7 with the vortex currents formed by this field in the anvil 8 results in displacement of the anvil 8 from the working surface of the coil 7. The rod with the locking sleeve 2 is displaced together with the anvil 8. The working working gas from the cavity C is supplied to the inlet channels D and further to the discharge gap of the magnetoplasma compressor. It should be noted that due to such an embodiment of the locking unit and the gas injector inlet channels, radial injection of the working gas is carried out, i.e. the flow of the injected gas is directed perpendicular to the axis of the plasma source directly into the zone of ionization. After termination of the control pulse in the winding of the coil 7, the locking sleeve 2 is returned to the initial position under the influence of elastic force of the damping unit 9.

## GASDYNAMIC AND ELECTROTECHNICAL CHARACTERISTICS OF THE WORKING SUBSTANCE INJECTOR OF THE MPC DURING OPERATION USING NITROGEN

Experimental studies of the pulsed injector for the working substance of MPC were aimed at determining the total amount of the gas supplied by the system, gas pulse shape and its duration, maximum value of the gas pressure in the flow, and determining the electrotechnical parameters of the current loop for the electromagnetic coil. The parameters of the gas pulse in time and its duration under different initial conditions, its configuration, dynamics of the gas pressure in time, maximum value of the gas pressure in the flow were studied using the piezoelectric pressure sensor. The pressure sensor was placed through the vacuum input of the vacuum chamber diagnostic window. In most measurements, the pressure sensor was placed at the distance of 2 cm from the outlet of the inlet channel. Calibration of the pressure sensor and measuring circuit showed sensitivity of 0.2 atm/V. The magnitude of the current in the winding of the control electromagnetic coil was measured using the Rogowski coil.

In this section, the results of research on the operation modes of the pulsed injector for the working substance of MPC using nitrogen as the working gas at different values of gas pressure in the booster cavity and at the variation of current and voltage values on the control coil are presented. Fig. 3 shows typical waveforms obtained from the piezoelectric pressure sensor 1 and current values 2 of the injector electromagnetic coil winding at the voltage of the control pulse on the coil terminals of 2 kV, nitrogen pressure in the booster cavity of the MPC gas injector of 25 atm.

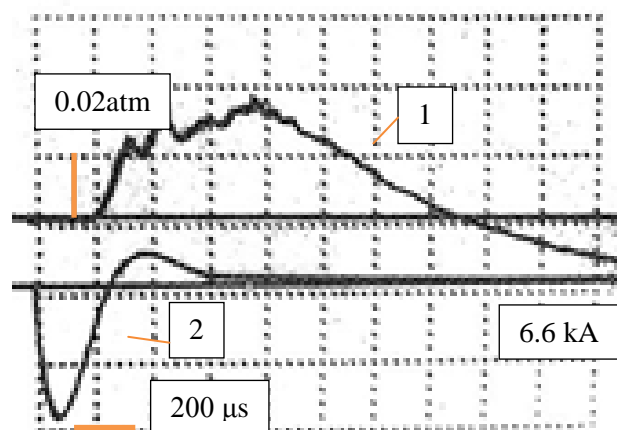

Fig. 3. Waveforms obtained from the piezoelectric pressure sensor 1 and current values 2 of the injector electromagnetic coil winding at the voltage of the control pulse on the coil terminals of 2 kV, nitrogen pressure in the booster cavity of the MPC gas injector of 25 atm

From the analysis of the waveform it follows that the first half period of the current in the winding of the control electromagnetic coil (during which the gas injector locking sleeve is opened) is 240  $\mu$ s. When applying the voltage of 2 kV to the coil, the maximum current in the winding of the electromagnetic coil was 11.9 kA. The injector power supply system is designed in such a way that the discharge current in the winding of the coil was

a oscillatory-damped with a large damping decrement. The waveform of the current pulse shows that the amplitude of the current in the coil winding in the second half period is only about 20% of the current amplitude in the first half period and does not significantly affect the operation of the locking unit.

The gas front at the outlet of the gas supply channels is recorded in about 220  $\mu\text{s}$  after initiation of the current pulse in the coil winding. The gas pressure reaches the maximum value of 0.03...0.035 atm in 420  $\mu\text{s}$  after initiation of the current pulse and for the period of about 400  $\mu\text{s}$  is not significantly changed. During this period of time, high voltage should be supplied to the electrodes of MPC for ignition of the main discharge and plasma formation. After 800  $\mu\text{s}$  the gas pressure starts to decrease and after 1300  $\mu\text{s}$  the pressure curve crosses the zero line (negative values of the piezoelectric pressure sensor correspond to the signal reflected from the rare wall of the sensor enclosure). Integral overlap of nitrogen per pulse was 25  $\text{cm}^3$  (at the atmospheric pressure) at the total duration of the gas pulse of 1300  $\mu\text{s}$ .

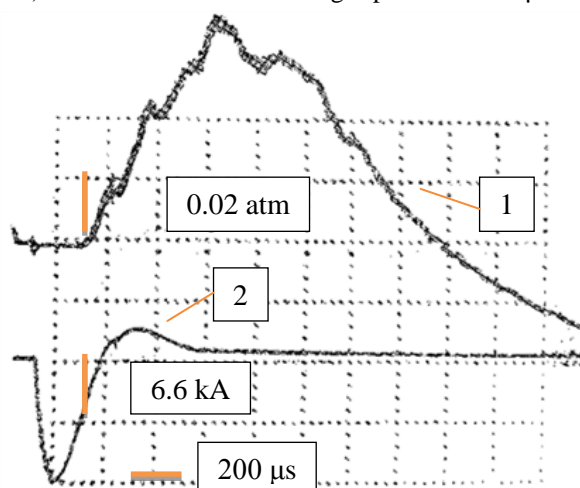

Fig. 4. Waveforms obtained from the piezoelectric pressure sensor 1 and current values of the electromagnetic coil winding 2 at the voltage of the control pulse on the coil of 2.5 kV, nitrogen pressure in the booster cavity of the MPC gas injector of 30 atm

For comparison, Fig. 4 shows the similar waveform for the voltage at the terminals of 2.5 kV coil and the nitrogen pressure in the booster cavity of 30 atm. From the analysis of the above waveforms, it can be concluded that the change of the voltage across the terminals of the electromagnetic coil and the magnitude of the initial nitrogen pressure in the booster cavity significantly affects the electrotechnical and gas-dynamic characteristics of the MPC gas injector. Thus, as the voltage increases up to 2.5 kV and the initial pressure increases up to 30 atm, the maximum amplitude of the current in the coil winding was 13.2 kA (in comparison with the previous operation mode, it increased by 11%). The gas pressure in the measurement zone reaches the maximum value of 0.075 atm in 700  $\mu\text{s}$  (increased by more than 2 times). Thus, the optimum values of the delay between the supply of the current pulse to the injector coil winding and initiation of the discharge in the MPC channel are displaced in this case towards later time in comparison with the previous mode. After 700  $\mu\text{s}$ , the gas pres-

sure starts decreasing. The integral supply of nitrogen was 56  $\text{cm}^3$  (at the atmospheric pressure) (the increase by more than 2 times) at the total duration of supply of 1450  $\mu\text{s}$  (the increase by about 150  $\mu\text{s}$ ).

Fig. 5 shows the dependence of the integral supply of nitrogen on the voltage value for the capacitor bank of the power supply system for the control coil of the MPC injector for different values of nitrogen pressure in the booster cavity of the gas injector changed within the range of 15...30 atm. Analysis of the presented above dependencies allows to make the conclusion that the gas injector is universal and allows varying the supply of the work gas in a wide range depending on the specific operation mode of the plasmodynamic system from 2  $\text{cm}^3$  (at the atmospheric pressure) to 70  $\text{cm}^3$ .

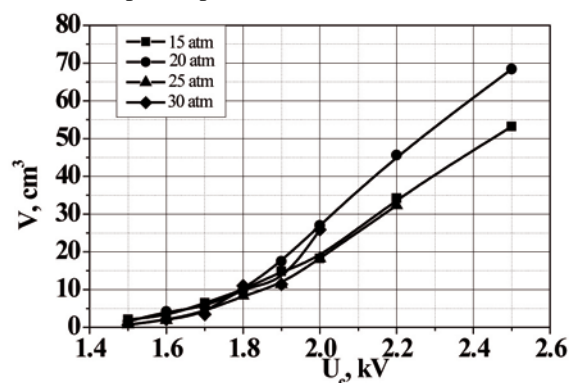

Fig. 5. Dependence of the integral supply of nitrogen on the voltage value at the MPC injector coil terminals for different values of nitrogen pressure in the booster cavity

The presented experimental dependences allow selecting the optimal operation modes of MPC. In particular, it is important to select the moment for initiation of the main discharge, start of working gas ionization in the acceleration channel and coordination of the gas injection systems and the main discharge. Variation of the gas supply values, pressure in the gas flow, values for initial gas pressure in the booster cavity in a wide range is the effective method of such optimization.

## CONCLUSIONS

The pulsed injector for the plasma-forming substance of the magnetoplasma compressor with electrodynamic coil of the locking unit and with radial supply of the working gas to the ionization zone was developed, manufactured and studied. A new technical solution for formation of the compact gas pulse due to the relief of the injector locking unit from the gas pressure was proposed. This allows variation of the initial working gas pressure in the booster cavity within a wide range (1...30 atm). The change the value of the gas pressure in the booster cavity of the presented embodiment of the gas injector is an effective way of adjustment of the integral working gas supply, gas pulse configuration and pressure gradient in the gas flow. The results of experimental research have shown large capabilities of the injector by the injected gas volume – from 1 to 70  $\text{cm}^3$  (at the atmospheric pressure) per pulse. A wide range of the gas-dynamic parameters allows using the device as the injector of the plasma-forming substance for the plasmodynamic systems both of compression and accel-

eration type at the duration of plasma generation from 10 to 500  $\mu$ s.

Relief of the injector locking unit from the gas pressure allows significant reduction of the dynamic forces which appear in the unit during its operation. This factor allowed the increase of operating life, efficiency and reliability of the working substance injector, that previously limited the use of such injectors in such high-speed plasmodynamic systems as magnetoplasma compressor.

## REFERENCES

1. V.I. Tereshin et al. Using the powerful quasi-stationary plasma accelerators for simulation of extreme plasma loads in a fusion reactor // *Encyclopedia of low-temperature plasma*. 2007, v. 9, p. 392-436.
2. I.E. Garkusha et al. The latest results from ELM-simulation experiments in plasma accelerators // *Physica Scripta*. 2009, v. 139, p. 014054.
3. I. Garkusha et al. Simulation of tungsten armour cracking due to small ELMs in ITER // *Fusion Engineering and Design*. 2010, v. 85, p. 1697-1701.
4. V.A. Makhraj et al. Dust generation mechanisms under powerful plasma impacts to the tungsten surfaces in ITER ELM simulation experiments // *Journal of Nuclear Materials*. 2013.
5. V.I. Tereshin et al. // *Vacuum*. 2004, v. 73(3-4), p. 5556-560.
6. V.I. Tereshin et al. // *Rev. Sci. Instr.* 2002, v. 53(2), p. 831.
7. I.E. Garkusha et al. // *Vacuum*. 2000, v. 58 (2), p. 195-201.
8. J. Langner et al. // *Surf. Coat. Techn.* 2000, v. 128-129, p. 105-111.
9. V.V. Chebotarev et al. // *Journal of Nuclear Materials*. 1996, v. 233-237, p. 736-740.
10. I.E. Garkusha et al. // *Journal of Nuclear Materials*. 2011, v. 415 (1), p. S65-S69.
11. I.E. Garkusha et al. // *Phys. Scr.* 2009, v. T138, p. 14054.
12. I.S. Landman et al. // *Phys. Scr.* 2004, v. T111, p. 206-212.
13. V.I. Tereshin et al. // *Brazilian Jour. of Phys.* 2002, v. 32 (1), p. 165-171.
14. A.K. Marchenko et al. Formation of the compression zone in the magnetoplasma compressor operating on heavy gases // *Problems of Atomic Science and Technology*. 2010, № 6, p. 94-96.
15. I.E. Garkusha et al. Characteristics of the discharge and dynamics of the compression plasma flows generated by MPC of compact geometry // *Plasma Physics Reports*. November 2011, v. 37, № 11, p. 1015-1022.
16. I.E. Garkusha et al. Investigation of pinching discharges in MPC device operating with nitrogen and xenon gases // *Czechoslovak Journal of Physics*. 2006, v. 56, № 2, p. B335-B341.
17. V.V. Staltsov et al. High-speed gas injector for powerful plasmodynamic systems // *Problems Atomic Science and Technology. Series "Plasma Physics"*. 2015, № 1 (95), p. 118-121.

Article received 08.06.2015

## ИМПУЛЬСНЫЙ ИНЖЕКТОР РАБОЧЕГО ВЕЩЕСТВА ДЛЯ МАГНИТОПЛАЗМЕННОГО КОМПРЕССОРА

*В.В. Стальцов*

Приведено техническое описание быстродействующего импульсного инжектора рабочего вещества с радиальной подачей газа для магнитоплазменного компрессора. Приведены результаты исследований основных газодинамических и электротехнических характеристик газового инжектора.

## ІМПУЛЬСНИЙ ІНЖЕКТОР РОБОЧОЇ РЕЧОВИНИ ДЛЯ МАГНІТОПЛАЗМОВОГО КОМПРЕССОРА

*В.В. Стальцов*

Наведено технічний опис швидкодіючого імпульсного інжектора робочої речовини з радіальним поданням газу для магнітоплазмового компрессора. Наведено результати досліджень основних газодинамічних та електротехнічних характеристик газового інжектора.